

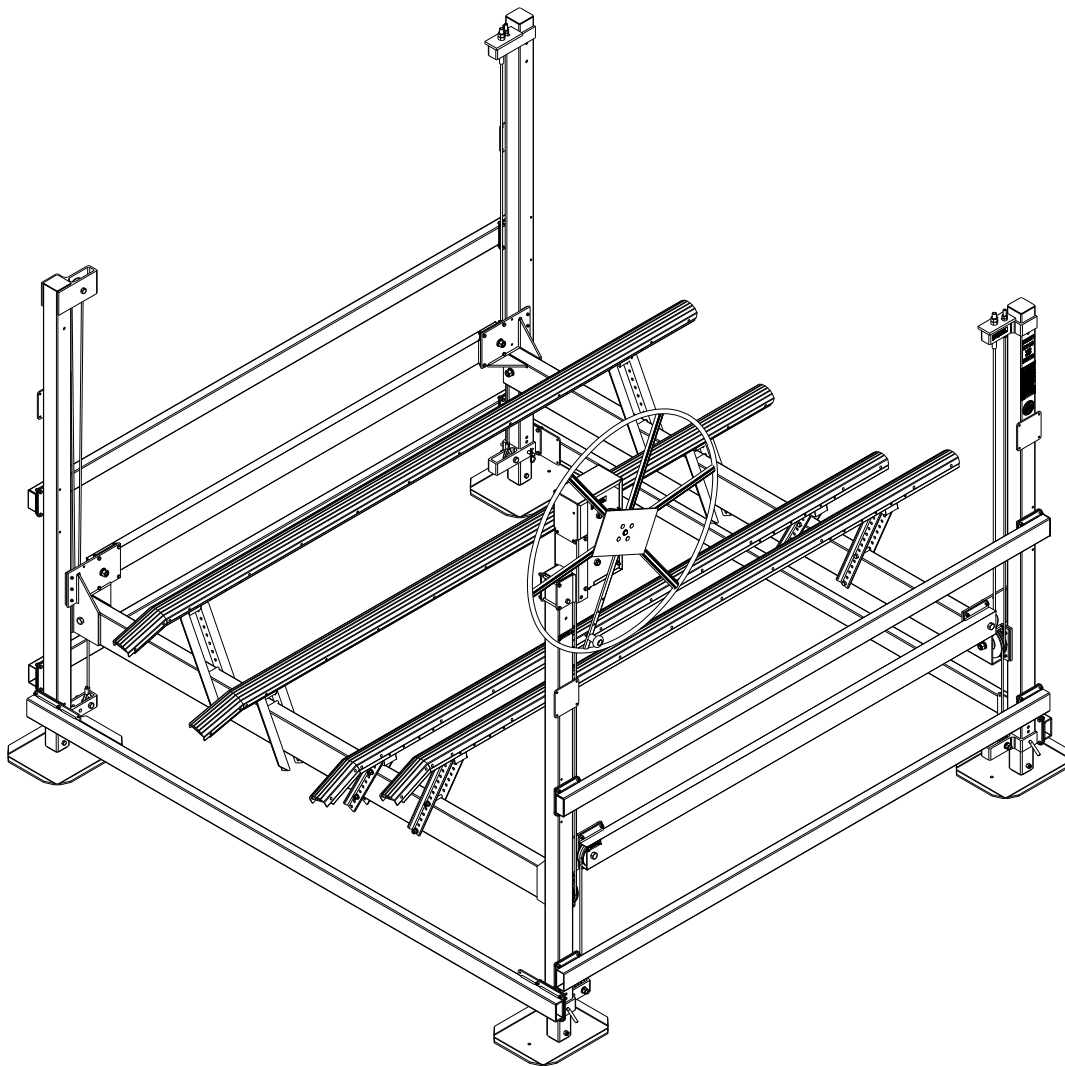

VLS60124, VLS60124T, VLS80124T, VLS100132T

VERTICAL LIFT INSTRUCTIONS

(Applies to P/N 3654495, 3654496, 3654499, 3654500)



Contents

| | | |
|--------|--|----|
| 1. | SAFETY | 4 |
| 1.1. | INTRODUCTION | 4 |
| 1.2. | SAFETY DEFINITIONS | 4 |
| 1.3. | EQUIPMENT SAFETY LABELS | 4 |
| 1.4. | EQUIPMENT AND PERSONAL SAFETY | 4 |
| 1.5. | INSTALLATION SAFETY | 5 |
| 1.6. | OPERATING SAFETY | 5 |
| 1.6.1. | General | 5 |
| 1.6.2. | Safety When Raising the Boat | 5 |
| 1.6.3. | Safety When Lowering the Boat | 6 |
| 1.7. | MAINTENANCE AND STORAGE SAFETY | 6 |
| 2. | SPECIFICATIONS | 7 |
| 2.1. | TECHNICAL DATA | 7 |
| 2.2. | NAMEPLATE AND SERIAL NUMBER TAG | 7 |
| 2.3. | OPTIONAL EQUIPMENT | 8 |
| 3. | INSTALLATION AND SETUP | 9 |
| 3.1. | PRE-INSTALLATION CHECKS | 9 |
| 3.2. | PRIOR TO SETUP | 10 |
| 3.3. | VERTICAL LEG ASSEMBLY | 11 |
| 3.4. | FRAME SIDE ASSEMBLY | 12 |
| 3.5. | PLATFORM ASSEMBLY | 13 |
| 3.6. | MOUNTING THE PLATFORM TO THE FRAME | 14 |
| 3.7. | PLATFORM REEVING AND ADJUSTMENT | 16 |
| 3.8. | MOVING LIFT TO OPERATING POSITION | 17 |
| 3.9. | WINCH ASSEMBLY AND REEVING | 18 |
| 4. | OPERATION | 20 |
| 4.1. | BEFORE OPERATING THE LIFT | 20 |
| 4.2. | TESTING WINCH OPERATION | 20 |
| 4.3. | RAISING AND LOWERING THE PLATFORM | 21 |
| 4.4. | SECURING LIFT WHEN NOT IN USE | 21 |
| 5. | INSPECTION AND MAINTENANCE | 22 |
| 5.1. | GENERAL MAINTENANCE RULES | 22 |
| 5.2. | WIRE ROPE INSPECTION PROCEDURE | 22 |
| 5.3. | ANNUAL INSPECTION | 23 |
| 5.4. | ANNUAL WINCH MAINTENANCE | 23 |
| 5.5. | STORAGE PROCEDURE | 23 |
| 6. | TROUBLESHOOTING | 24 |
| 7. | PARTS LISTS | 25 |

PRE-LIFTING CHECKLIST

The lift and related equipment must be thoroughly inspected prior to each use. Only those who have read and understood this entire manual and related equipment manuals are qualified to do this inspection. This checklist is to be used as a guideline in conjunction with the maintenance and inspection procedures outlined in this manual. It is recommended that the inspection be maintained as a permanent record.

- Ensure the lift installation will clear all power lines and obstructions.
- Ensure all structural members of the lift are free of defects and damage that may affect the integrity.
- Ensure that an electric drive, if used, has been inspected and installed by a certified electrician in accordance with local electrical codes. A Ground Fault Circuit Interrupter (G.F.C.I.) must be installed by your electrician and work properly.
- Ensure that any user or dealer installed locking devices have been removed before operating the lift.
- Operate the lift first without, and then with, your boat on the platform to test the operation of both the lift and the winch.
- Ensure the boat is properly positioned on the lift before doing any raising or lowering.
- Ensure the lift is not being used beyond its rated capacity.
- Ensure any drain plug is in place on the boat before launching.
- Conduct the wire rope inspection procedure described in Chapter 5 at least monthly.
- Ensure the leg pins connect the vertical legs to the adjustable legs. Ensure the leg height has been properly adjusted according to the water depth.
- Ensure the frame and platform fastenings are tight.
- Ensure the frame is level and square according to the dimensions shown in Figure 3-8, Chapter 3.
- Ensure all of the wire rope end loops are fastened to the bracket at the bottom of each vertical leg.
- Ensure the wire rope studs opposite the cable end loops in the platform assembly are tight. If tightening is needed, follow the sequence described in Section 3.7 of Chapter 3. Then tighten the jam nuts to the cable nuts to lock the position.
- Ensure the winch is securely fastened to the vertical leg "A".
- Ensure the handwheel has been attached to the winch hubplate.
- Ensure the spinner knob is attached to the handwheel using the preassembled hardware.
- Ensure the A-B load tube wire rope stud is fastened to the vertical leg "B" to enable winch operation.
- Ensure set screw securing wire rope end to the drum is tight and in good condition.
- When facing the front of the handwheel, ensure that the wire rope winds and unwinds from the left side of the winch. This reeving will raise the platform when the handwheel is turned clockwise, and lower the platform when the handwheel is turned counter-clockwise. The brake pawl must click, meaning the brake is operating.
- Ensure the guards are in place before operating the winch.
- Ensure the plastic caps are installed onto the tops of the vertical legs and the ends of the upper short horizontal tubes.

1. SAFETY

1.1. INTRODUCTION

Your Reimann & Georger Corporation Marine Products Aluminum Vertical Lift has been engineered to provide lifting performance, long term economics and safety advantages that no other type can match. However, even a well-designed and well-built lift can malfunction or become hazardous in the hands of an inexperienced and/or untrained user. Therefore, read this manual and related equipment manuals thoroughly before operating your lift to provide maximum safety for all operating personnel, and to get the maximum benefit from your equipment.



WARNING:

DO NOT OPERATE THIS LIFT WITHOUT STUDYING THIS ENTIRE MANUAL. FAILURE TO DO THIS CAN LEAD TO EQUIPMENT MISUSE WITH RESULTING SERIOUS PERSONAL INJURY AND/OR DAMAGE. CONTACT YOUR RGC® MARINE DEALER IF YOU HAVE ANY QUESTIONS.

1.2. SAFETY DEFINITIONS

A safety message alerts you to potential hazards that could hurt you or others or cause property damage. The safety messages or signal words for product safety signs are **DANGER, WARNING, and CAUTION**. Each safety message is preceded by a safety alert symbol and is defined as follows:

DANGER: Indicates an imminently hazardous situation that, if not avoided, **will** cause death or serious injury. This safety message is limited to the most extreme situations.

WARNING: Indicates a potentially hazardous situation which, if not avoided, **could** result in death or serious injury.

CAUTION: Indicates a potentially hazardous situation which, if not avoided, **may** result in minor or moderate injury. It may also be used to alert against unsafe practices and property-damage-only accidents.

1.3. EQUIPMENT SAFETY LABELS

These labels warn you of potential hazards that could cause injury. Read them carefully. If a label comes off or becomes illegible, contact a Reimann & Georger Corporation dealer for a free replacement.

1.4. EQUIPMENT AND PERSONAL SAFETY

1. Do not use the lift if it shows any signs of damage.
2. Do not exceed the rated maximum lifting capacity of this equipment.
3. When using a direct drive or motorized friction drive, understand the use of all controls and connections provided with it.



WARNING:

ALL ELECTRIC DRIVES MUST BE INSTALLED AND INSPECTED BY A CERTIFIED ELECTRICIAN IN ACCORDANCE WITH LOCAL ELECTRICAL CODES. THIS INSTALLATION MUST INCLUDE A PROPERLY WORKING GROUND FAULT CIRCUIT INTERRUPTER. (G.F.C.I.)

4. Never try lifting anything other than a boat with this equipment.
5. Never allow people in the boat any time it is suspended above the water on the platform.



WARNING:

DO NOT STAND OR WALK ON THE PLATFORM WHILE IT IS IN ANY RAISED POSITION. THIS CAN CAUSE SERIOUS PERSONAL INJURY.

6. Do not allow anyone to swim or play under, near or on the lift at any time.

1.5. INSTALLATION SAFETY

1. Ensure that all bolts and nuts are fastened securely prior to operation.
2. Ensure the pulleys spin freely. If any pulley binds, replace it immediately.
3. Do not weld or otherwise modify the lift. Such alterations may weaken the structural integrity of the lift and void the warranty.
4. All lifting accessories such as pontoon brackets, pivoting bunks, and guide-ons, must be commercially manufactured, have a rated load capacity equal to that of the lift, and be properly maintained and installed.
5. Ensure that the frame is level and square.
6. The following precautions must be observed when lifting any part of this equipment:
 - a. Be sure of your footing.
 - b. Bend your knees and lift with your legs.
 - c. Hold the equipment section close to your body when lifting.
7. Wear heavy leather gloves when handling wire rope. Insufficient hand protection when handling wire rope can cause personal injury.

1.6. OPERATING SAFETY

1.6.1. General

1. Never use this equipment beyond its rated capacity. This can damage the lift and/or boat with resulting serious personal injury.
2. Before allowing anyone to operate the lift, be certain they fully understand the proper operating procedure.
3. Completely remove any user or dealer installed locking devices before operating the lift.
4. Follow the Pre-Lifting Checklist before operating.
5. Do not try lifting or launching your boat in rough water conditions. This can damage your boat and/or the lift.
6. The boat must be secured on the lift before raising or lowering. Failure to do this can cause equipment damage and/or serious personal injury.
7. Keep people and pets clear during operation of the lift.
8. Keep fingers and clothing clear of all moving parts.
9. Check the lift periodically for frayed wire ropes and/or binding pulleys.
10. Do not attempt to make any adjustments on the lift while it is being operated.
11. Contact your dealer if the winch mechanism fails to perform as described in the Operation chapter of this manual.
12. Never tamper with the winch mechanism. This can cause equipment damage.
13. Do not operate the lift under the influence of drugs, alcohol, or medication.
14. Never use the lift to hang or store any auxiliary equipment such as boating hardware.

1.6.2. Safety When Raising the Boat

1. The handwheel or power drive must turn clockwise when raising the platform. The brake pawl must click, indicating that the brake is operative.
2. Do not try to raise the boat beyond the maximum lifting height of the platform.



WARNING:

IF YOU HAVE TO TURN THE HANDWHEEL COUNTERCLOCKWISE TO RAISE THE PLATFORM, YOU HAVE REEVED THE WINCH INCORRECTLY. YOU WILL IMMEDIATELY ENCOUNTER STRONG RESISTANCE WHICH CAN LEAD TO WINCH DAMAGE AND/OR WIRE ROPE BREAKAGE.

1.6.3. Safety When Lowering the Boat

1. The handwheel or power drive must turn counter-clockwise when lowering the platform.



WARNING:

IF YOU HAVE TO LOWER THE PLATFORM BY TURNING THE HANDWHEEL CLOCKWISE, YOU HAVE REEVED THE WINCH INCORRECTLY. THE BRAKE PAWL WILL NOT BE EFFECTIVE WHICH CAN CAUSE AN UNCONTROLLED SPIN-DOWN OR “FREEWHEEL” OF THE HANDWHEEL. IF FREEWHEELING OCCURS, NEVER TRY TO STOP IT.

2. Counter-clockwise rotation of the handwheel allows the self-activating brake mechanism to provide a controlled lowering of the platform.



WARNING:

NEVER RELEASE THE BRAKE PAWL OF THE WINCH. THIS CAN TRIGGER AN UNCONTROLLED SPIN-DOWN OR “FREEWHEEL” OF THE HANDWHEEL.

3. Do not continue lowering the platform after the boat floats freely. Excessive slack in winch cable may cause binding.

1.7. MAINTENANCE AND STORAGE SAFETY

1. At least once a year, the lift must be thoroughly inspected as described in the Maintenance chapter of this manual.
2. Completely lower the platform before performing any type of maintenance or repair.



WARNING:

NEVER ALLOW ANYBODY TO WORK IN OR ON THE BOAT WHEN IT IS SUSPENDED ABOVE THE WATER ON THE LIFT.

3. Immediately replace any components found to be defective as described in Chapter 5—Inspection and Maintenance.

2. SPECIFICATIONS

2.1. TECHNICAL DATA

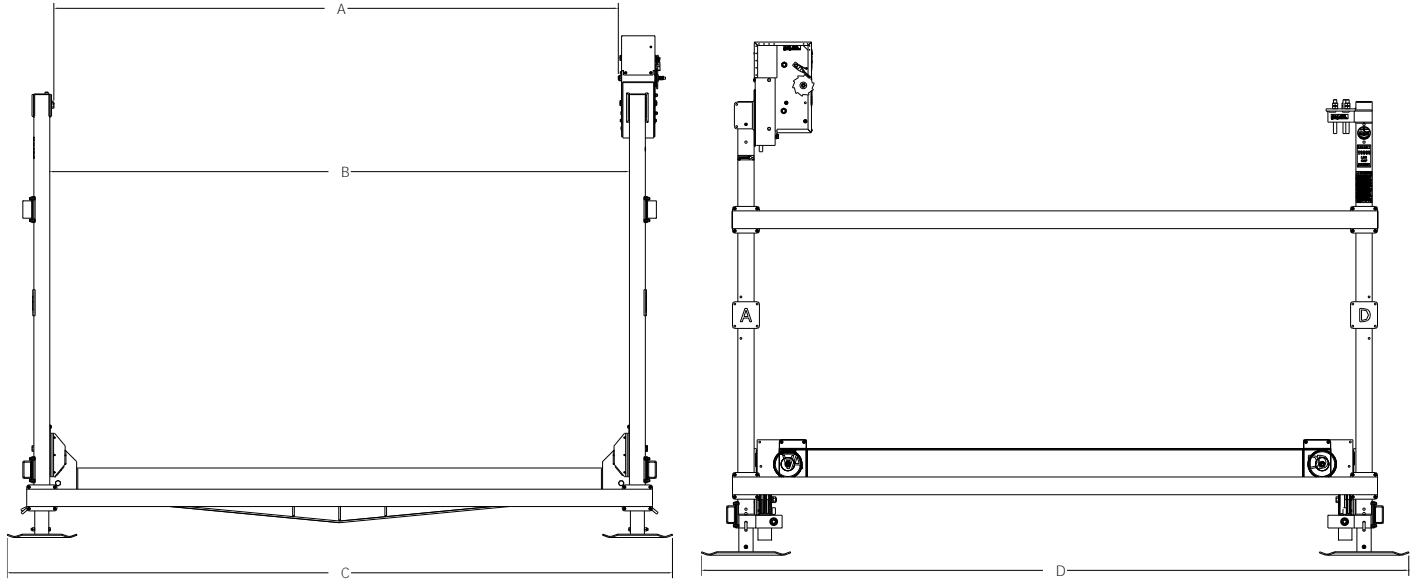

| Model | Weight Capacity (lbs) | Maximum Beam (in) A | Inside Width Between Legs (in) B | Cradle Travel (in) | Overall length (in, incl. feet) D | Overall width (in, incl. feet) C | Minimum platform height (in) | Standard Winch | Approx. Shipping weight (lbs) |
|------------|-----------------------|---------------------|----------------------------------|--------------------|-----------------------------------|----------------------------------|------------------------------|----------------|-------------------------------|
| VLS60124 | 6,000 | 121 | 124 | 59 | 138 | 128 | 8 | R18LT | 590 |
| VLS60124T | 6,000 | 121 | 124 | 59 | 138 | 128 | 8 | R18LT | 610 |
| VLS80124T | 8,000 | 121 | 124 | 68 | 138 | 128 | 11 | R18LT | 665 |
| VLS100132T | 10,000 | 128 | 132 | 66 | 158 | 152 | 11 | R18HD | 1030 |

*Measured from top of load tube to bottom of feet when the adjustable legs are fully retracted.

Measurements are approximate.

All lifts include low-maintenance polymer sheaves, stainless steel hardware, and stainless wire rope.

Adjustable extension legs, vinyl-clad aluminum or carpeted wooden bunks, and manual or electric winch drive mechanism are required to complete installation.

2.2. NAMEPLATE AND SERIAL NUMBER TAG

It is important to identify your lift completely and accurately whenever ordering spare parts or requesting assistance in service. The lift has a product nameplate located at the top of vertical leg "D". The label shows the model and serial numbers and capacity rating. The lift label should appear as the sample nameplate shown. Record the model, serial number, and capacity rating in this manual for future reference.

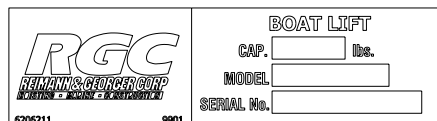

Typical Product Nameplate

MODEL: _____

SERIAL NUMBER: _____

CAPACITY RATING: _____

2.3. OPTIONAL EQUIPMENT

The following options are available which enable you to customize your lift for your particular operation. Installation instructions are provided as part of each option kit.

1. **Acrylic Canopy** – Boats tucked neatly under the heavy-duty canopy are protected from the elements, reducing the need for boat coverings. Various canopy sizes and colors are available.
2. **R18LT Direct Drive AC 110V** – For added ease of operation, a heavy-duty AC motorized direct drive mounts in place of the standard handwheel and lifts your boat out of the water. Exclusive right-angle design minimizes intrusion of dock space. An RC option is available.
3. **R18LT Direct Drive DC 24V** – For added ease of operation, a heavy-duty DC motorized direct drive mounts in place of the standard handwheel and lifts your boat out of the water. Exclusive right-angle design minimizes intrusion of dock space. An RC option is available.
4. **Friction Drive** – Motorized drive turns standard handwheel to raise and lower boat. An RC option is available.
5. **Full Length Pivoting Bunks** – Full length cushioned bunks cradle and center the boat for secure lifting.
6. **Full Length Guide-On** – Cushioned guide-ons make entering the lift easy in various water conditions.
7. **Motor Stop** – Assists in positioning boat on the lift for balanced lifting.
8. **Bow Stop** – Assists in positioning boat on the lift for balanced lifting.
9. **VL Transport Kit** – Makes installation and removal of boat lift easier. You can purchase the complete kit or desired components.
10. **Pontoon Deck Brackets** – These brackets are designed to lift pontoon boats from under the deck. The vertical leg bumper kit is included which supplies carpeted side bumpers. Wood for bunks is not supplied.
11. **Pontoon Cradles** – Cradle brackets designed for lifting pontoon boats from under the pontoons. The vertical leg bumper kit is included which supplies carpeted side bumpers. Wood for bunks is not supplied.
12. **Deep Water Extension Legs** – Adjustable legs available in pairs with bracing. Standard lengths are 3', 5', 7', and 9'.

3. INSTALLATION AND SETUP

3.1. PRE-INSTALLATION CHECKS

1. Do not assemble the lift if any part shows any sign of damage.
2. Do not weld or otherwise modify the lift. Such alterations may weaken the structural integrity of the lift and void the warranty.
3. This product has been supplied with stainless steel hardware to protect against a harsh marine environment and provide outstanding performance. Due to the chemistry and surface condition of stainless steel, there is a natural tendency for the hardware to “gall, lock up, or seize” during assembly. To prevent this from occurring, it is **highly recommended** that the anti-seize supplied in the hardware bag be applied to the mating surfaces of all stainless-steel fasteners before assembly. Lubricants containing molybdenum disulfide, graphite, mica or talc may also be used.



WARNING:

FAILURE TO APPLY A SUITABLE LUBRICANT TO THE MATING SURFACES OF STAINLESS STEEL THREADED FASTENERS MAY CAUSE GALLING AND/OR SEIZING OF ASSEMBLY.

4. All lifting accessories such as pontoon brackets, pivoting bunks, guide-ons, and slings shall be commercially manufactured, have a rated load capacity equal to that of the lift, and be properly maintained and installed. Consult the manufacturer’s separate instructions provided for these accessories.



WARNING:

ALL ELECTRIC DRIVES MUST BE INSTALLED AND INSPECTED BY A CERTIFIED ELECTRICIAN IN ACCORDANCE WITH LOCAL ELECTRICAL CODES. THIS INSTALLATION MUST INCLUDE A PROPERLY WORKING GROUND FAULT CIRCUIT INTERRUPTER. (G.F.C.I.)

3.2. PRIOR TO SETUP

The part reference numbers used in the subassembly drawings of sections 3.3 through 3.9 are the same as those in the parts lists of Chapter 7.

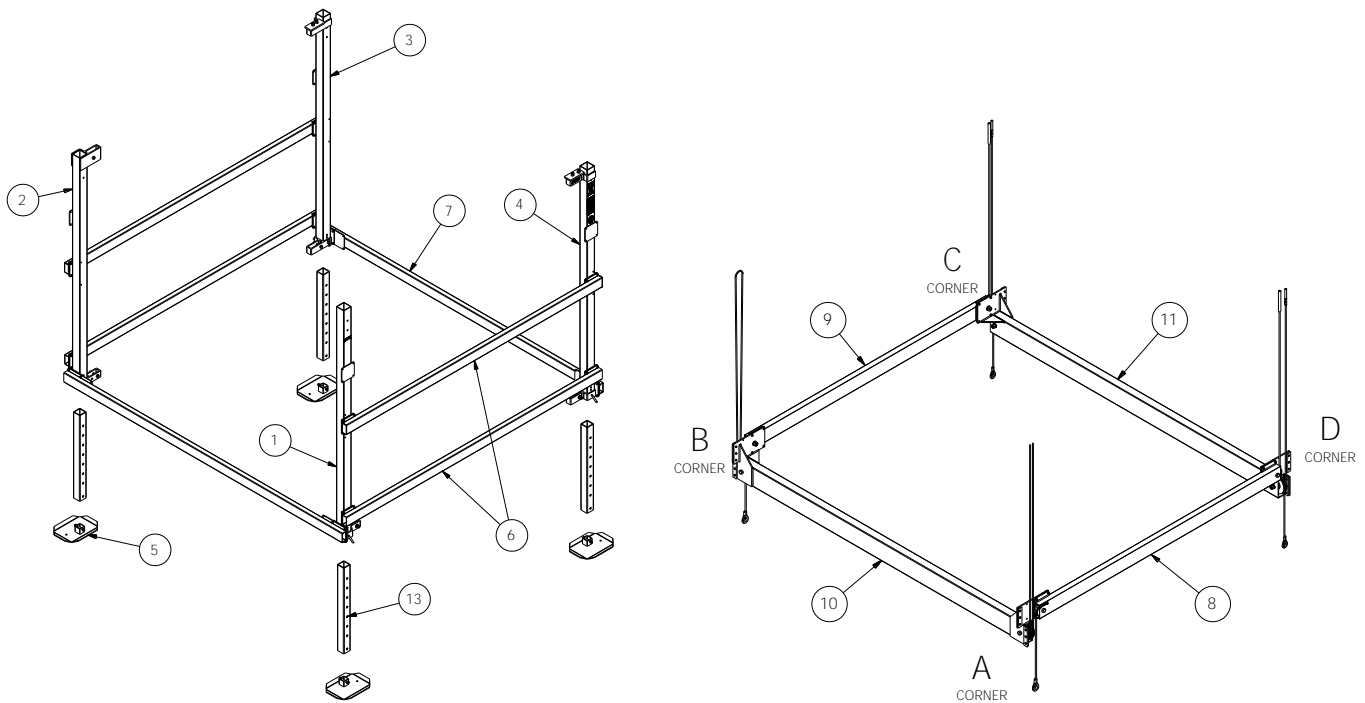

Vertical Lift Frame & Platform Assembly

The lift may be placed on either side of your dock as shown in Figure 3-2. The winch is mounted onto vertical leg A.

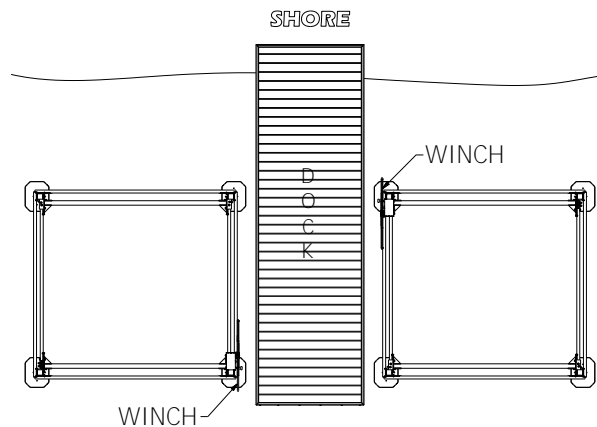

Lift / Dock Placement Options

Place one bag of hardware at each corner.



CAUTION:

INSERT ALL BOLTS FROM THE INSIDE OF THE LIFT TO PREVENT DAMAGE TO YOUR BOAT. THE NUTS FASTEN ONTO THE OUTSIDE FACE OF THE LIFT. THE ONLY BOLTS THAT MAY BE INSERTED FROM THE OUTSIDE OF THE LIFT ARE THOSE ON THE BOTTOM PARTS OF THE BRACES.

3.3. VERTICAL LEG ASSEMBLY

1. Fasten an adjustable extension leg onto each of the foot plates (5) using supplied hardware (47 & 59). Insert these subassemblies into the bottoms of each of the vertical legs A, B, C, and D.
2. Adjust the leg height according to water depth: the deeper the legs are in the water, the higher the vertical legs should be mounted onto the extension legs. Connect the extension legs to the vertical legs with supplied VL Hitch Pins (26). Secure the hitch pins (26) with cotter pins. (40)
3. Install (4) plastic caps (60) into the top opening of each vertical leg (1).

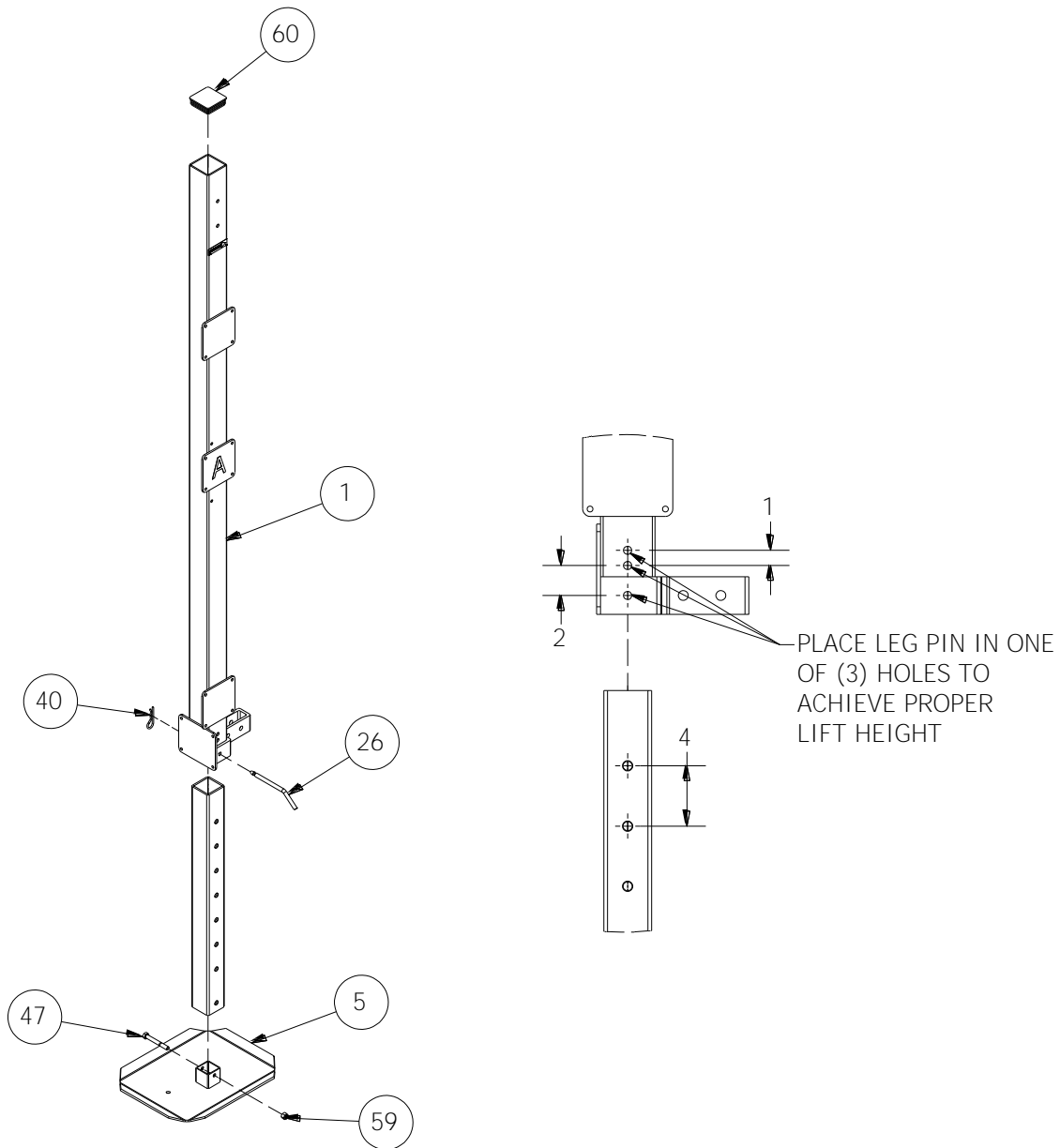

Vertical Leg Assembly

3.4. FRAME SIDE ASSEMBLY

1. Fasten a pair of short horizontal tubes (6) between vertical legs A and D with hardware shown (34 & 43). DO NOT TIGHTEN. Install (2) black caps (61) into ends of the top horizontals only.
2. Repeat the procedure for vertical legs B and C.
3. Lay the assembled sides down on the ground with the foot plates facing one another and aligned, about 9 feet apart.
4. Square the side assemblies by adjusting the verticals to achieve the same measured distance between them at both top and bottom. Tighten all fasteners. Re-measure and align if necessary.

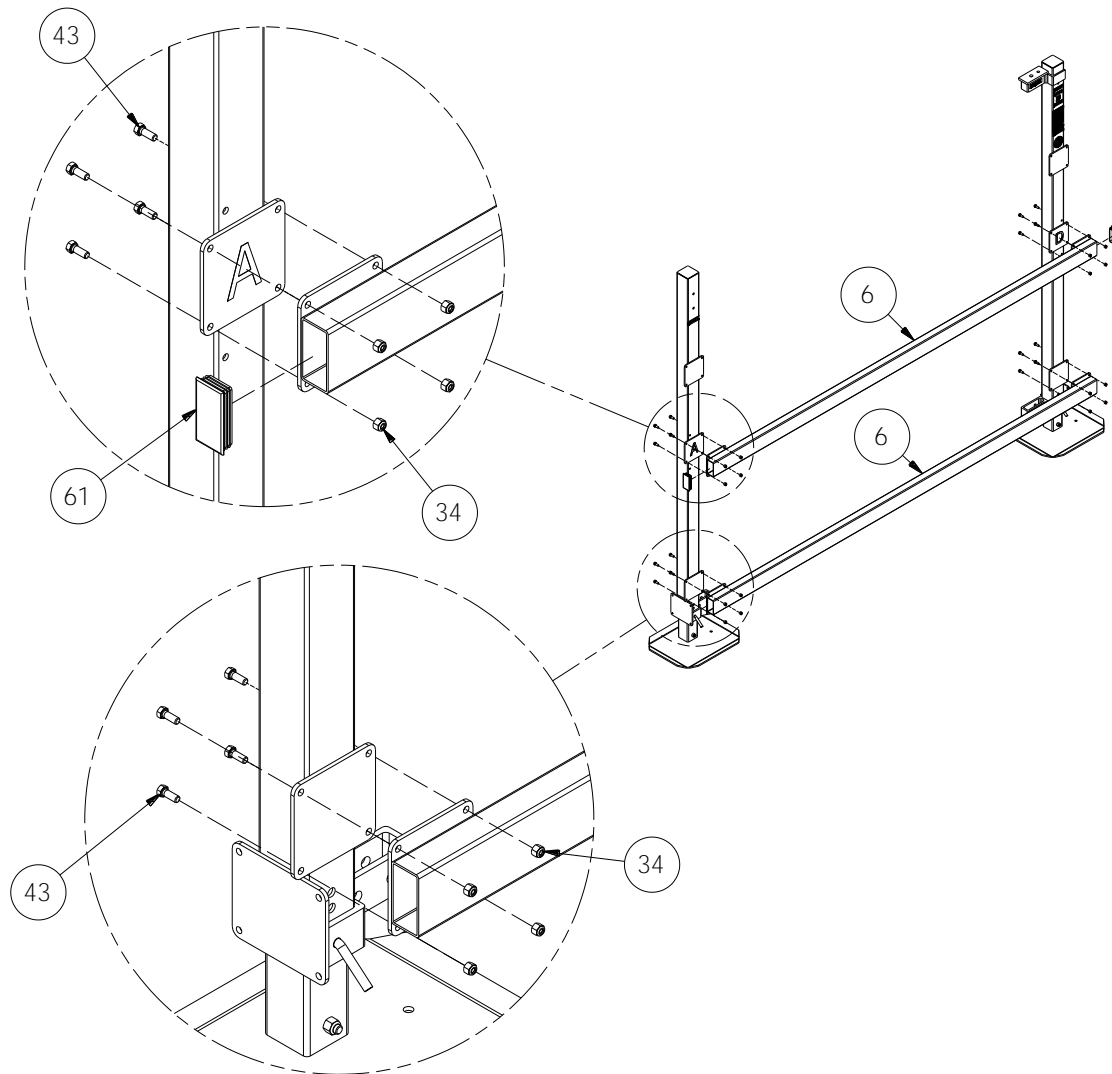

Frame Side Assembly

3.5. PLATFORM ASSEMBLY

1. Position both load tubes (10 & 11) and spreader tubes (8 & 9) on the ground as shown in the diagram.
2. Carefully remove the 5/8" hex nut and washers, if supplied, from each end of both spreader tubes, but DO NOT remove the bolts from the tubes. This will prevent the sheaves from falling out.
3. At each corner of the platform, align the holes in the spreader tube with the holes in the load tube. Fasten the tubes together with hardware shown (34 & 44). Then refasten the 5/8" hex nut and washers, if supplied.

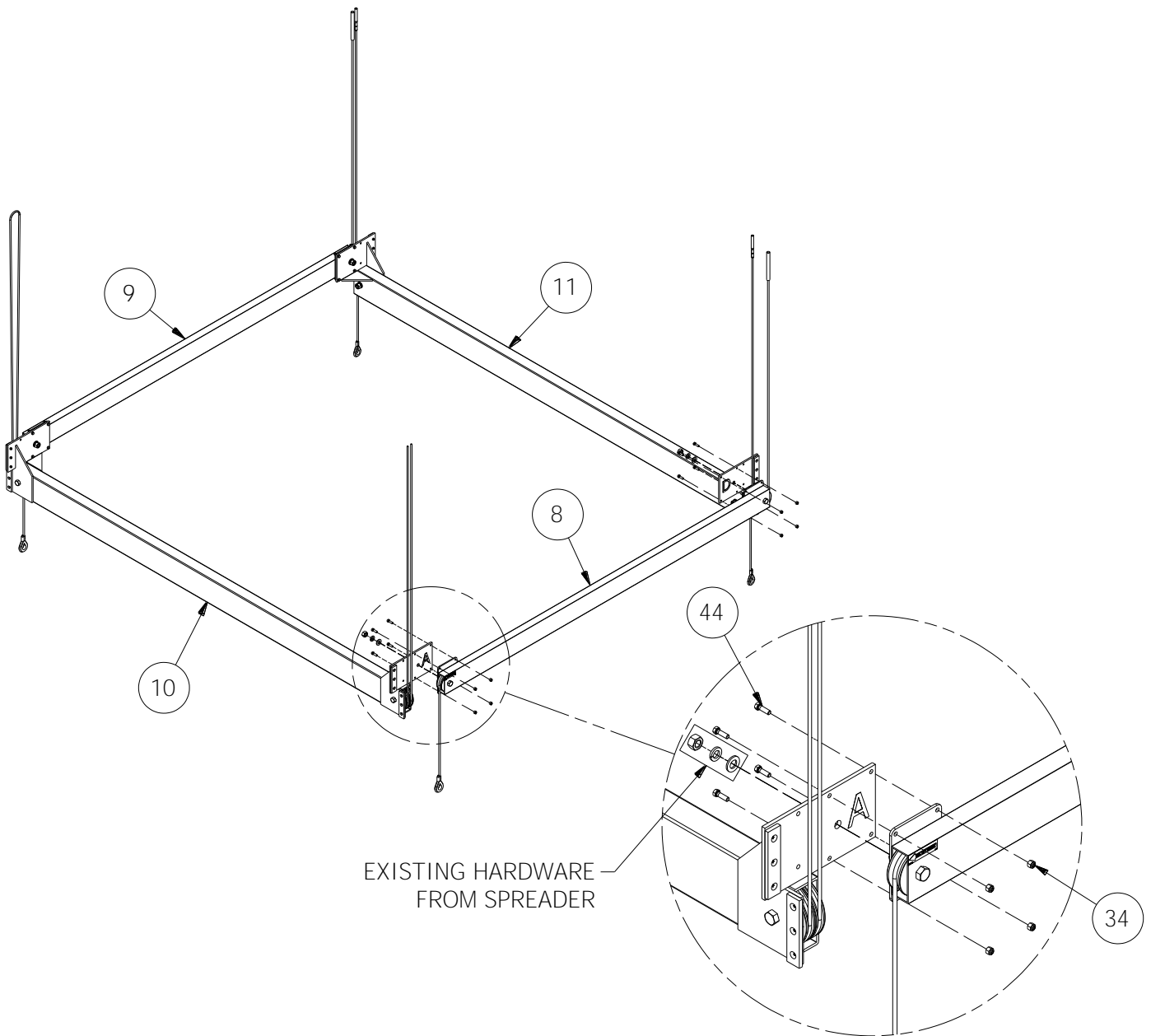

Platform Assembly – Top View

3.6. MOUNTING THE PLATFORM TO THE FRAME

1. Ensure all platform fastenings are tight before mounting onto the frame.
2. Arrange frames sides on ground with the feet facing the platform.

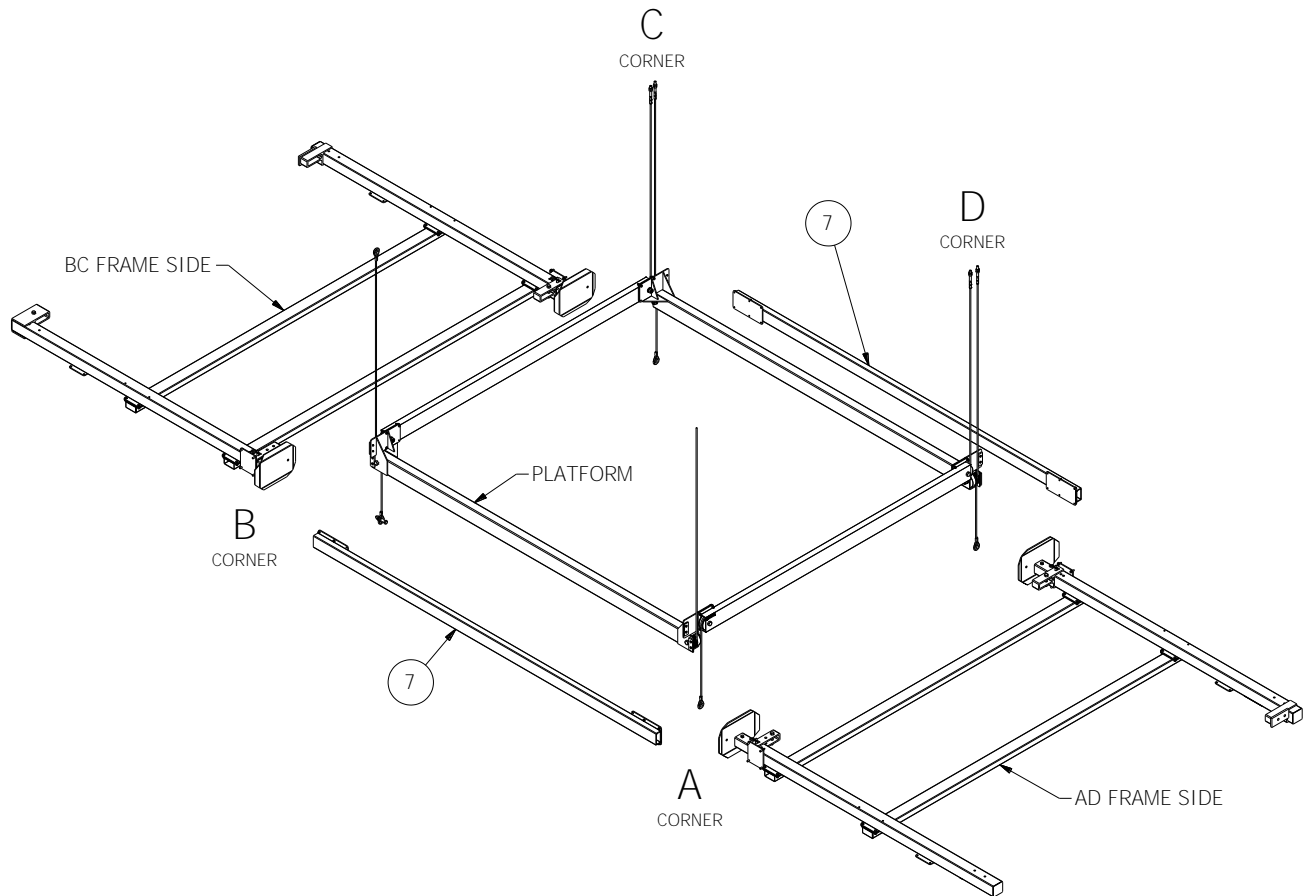

Layout of Assemblies to Assemble Frame

3. Lift one of the frame sides and position it along a spreader tube side of the platform.
4. Place a platform corner onto each of the foot plates so that the frame side stands.
5. Repeat Steps 2 and 3 for the other side of the lift.



CAUTION:

THE LOAD AND SPREADER TUBES OF THE PLATFORM ARE ALREADY REEVED. WHEN PLACING THE ASSEMBLED PLATFORM INTO THE FRAME, INSURE THE WIRE ROPE LOOPS ARE PASSING OVER THE SHEAVES AND POINTING TOWARDS THE BOTTOM BRACKET OF EACH VERTICAL LEG. EQUIPMENT MALFUNCTION AND DAMAGE WILL RESULT IF THE PLATFORM IS NOT ORIENTED THIS WAY.

6. Fasten a long horizontal tube (7) across each end to connect the two sides using hardware shown (34 & 43).
DO NOT TIGHTEN.

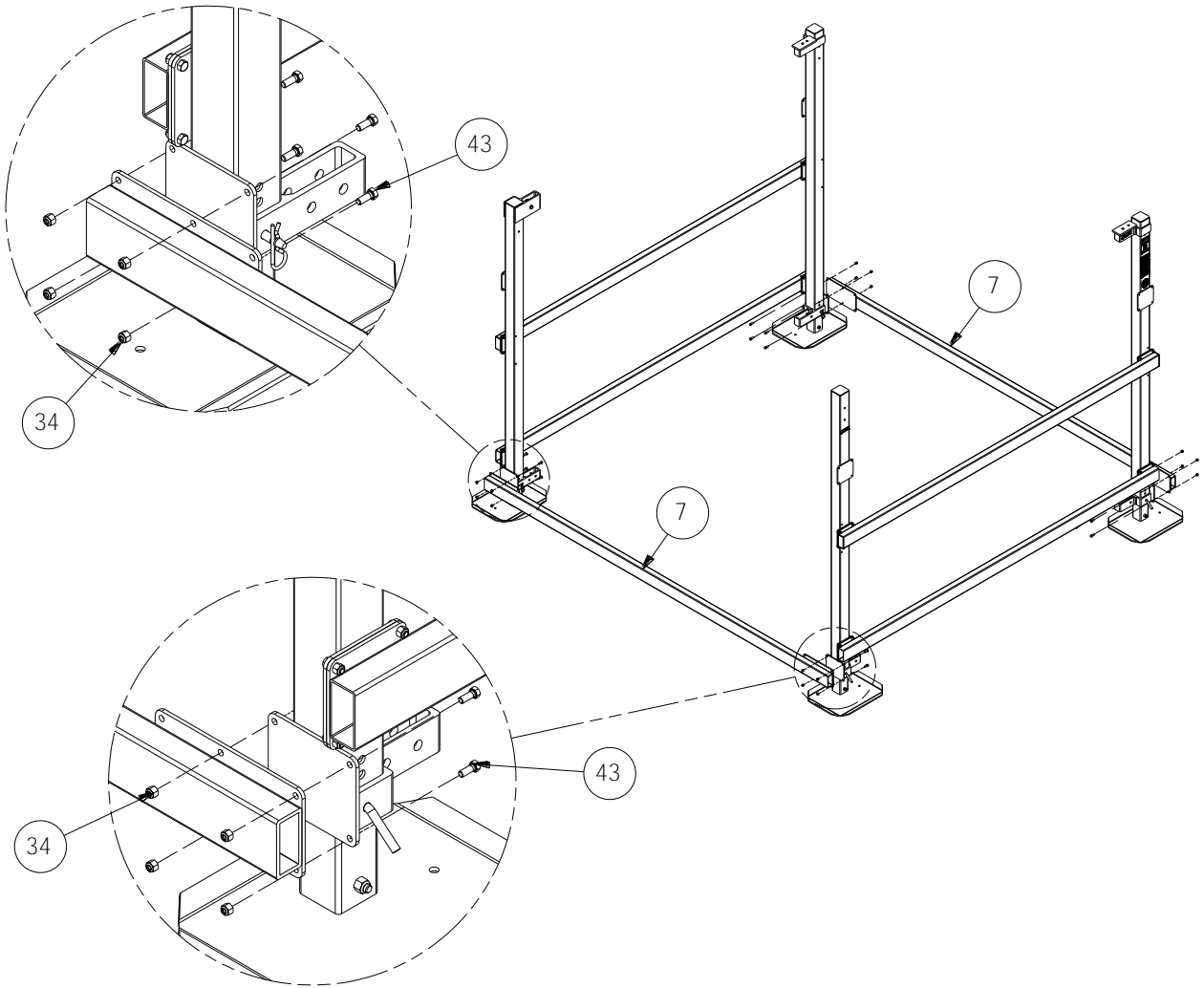

Assemble End Horizontal to Frame

7. Square the frame by adjusting the verticals to achieve the same measured distance between them at both top and bottom. Tighten all fasteners. Re-measure and align if necessary.

3.7. PLATFORM REEVING AND ADJUSTMENT

1. Position the platform near the bottom end of its lifting range. Ensure the platform is level.
2. The load tubes and spreader tubes are already reeved. Fasten the wire rope end loops to the bracket provided at the bottom of each of the four vertical legs. Do not overtighten! (33, 36, 37, & 38)



CAUTION:

WEAR HEAVY LEATHER GLOVES WHEN HANDLING WIRE ROPE. FAILURE TO DO THIS CAN CAUSE SERIOUS PERSONAL INJURY.

3. Using a 7/8" open-end wrench, tighten the wire rope studs opposite the wire rope end loops in the following order.

Step 1: Tighten down the nut (54) to add tension to the B-C spreader tube wire rope.

Step 2: Tighten down the nut (54) to add tension to the A-D spreader tube wire rope. Check that the B-C and A-D spreader tube wire ropes are equal in tension and that the platform is level.

Step 3: Tighten down the nut (55) to add tension to the first C-D load tube wire rope.

Step 4: Tighten down the nut (55) to add tension to the second C-D load tube wire rope. Check that both C-D load tube cables are equal in tension and that the platform is level.

4. Add and tighten the jam nuts (54 & 55) to the wire rope nuts to lock the position.
5. During operation, when the platform is being lifted, it is normal for the two wire ropes in the C-D load tube to alternate from being tense to going slack. If you notice this, it is not necessary to further tighten down the nuts.
6. If the boat is not lifting level because the stern is lifting higher or lower than the bow, the spreader tube wire ropes are not tight enough. Repeat the first two sub-steps under Step 3 above.

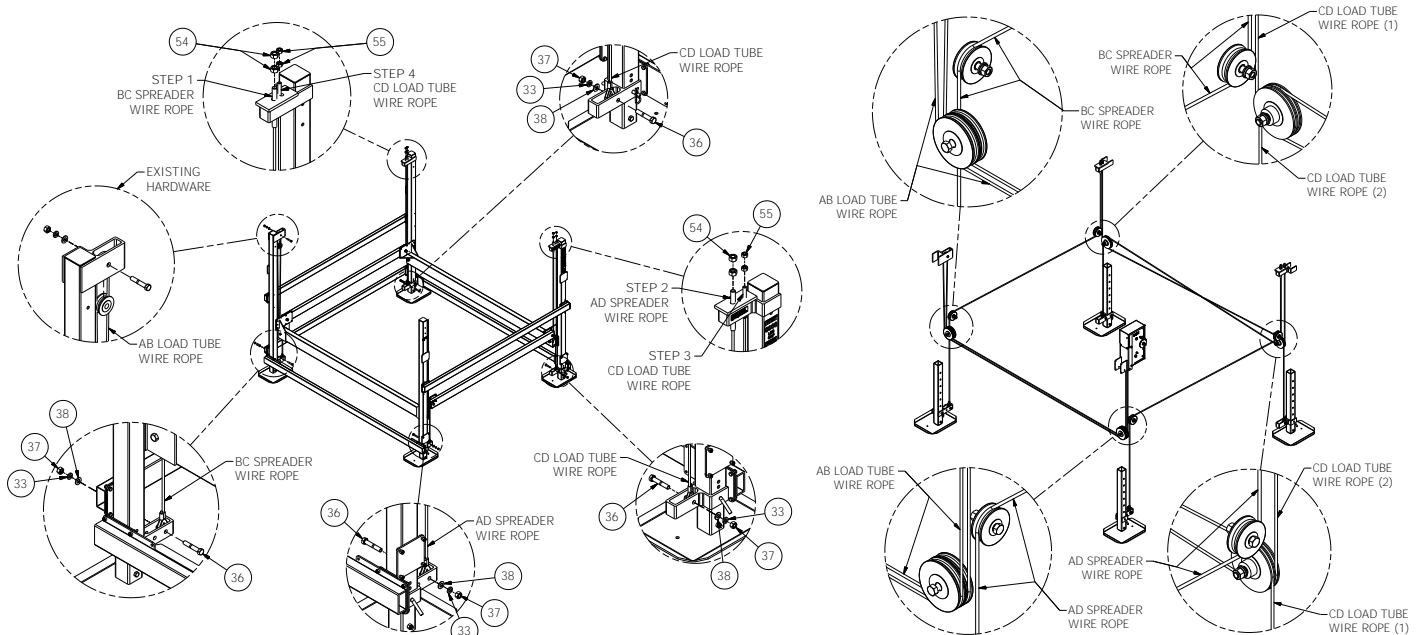

Cable Reeving & Adjustment

3.8. MOVING LIFT TO OPERATING POSITION

1. The following precautions must be observed when moving your lift for any reason:
 - a. Be sure of your footing.
 - b. Bend your knees and lift with your legs.
 - c. Hold the lift section close to your body when lifting.
2. After moving your lift to the operating position, ensure that the frame is square and that the lift sets level.



CAUTION:

SEVERE OUT OF LEVEL INSTALLATION MAY CAUSE BINDING, RESULTING IN EQUIPMENT DAMAGE.



CAUTION:

FRAME MUST BE SQUARE TO PREVENT DAMAGE AND/OR IMPROPER FITTING OF CANOPY FABRIC IF SO EQUIPPED.

3. Verify frame is square by measuring the diagonal distance from the outside of frame corner to opposite corner. Repeat for alternate corners. The **difference between the two measurements shall not exceed 1/4 of an inch.**

Frame Diagonal Measurement Diagram

(Measure to Outside Corners)

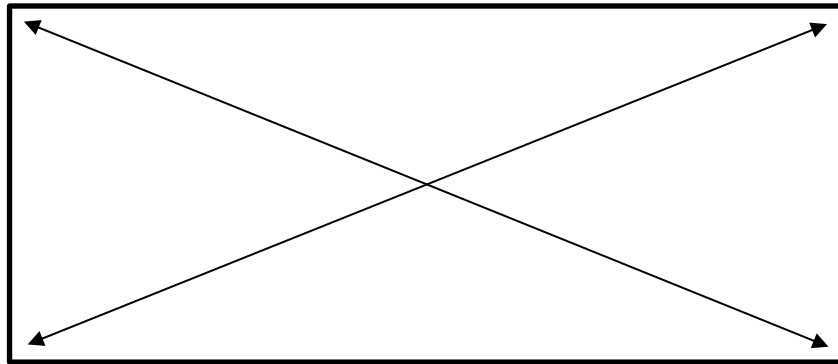

3.9. WINCH ASSEMBLY AND REEVING

3.9.1. Winch Assembly

1. Clamp winch (13) to vertical leg "A" using hardware shown (28, 29, 31, 32, 46, 48, 56, 57). Mount the winch such that any optional canopy cover will not interfere with removing and replacing the winch cover.
2. Attach the handwheel (24) to the winch adapter plate (25) using hardware shown (34 & 42). Install handwheel adapter (25) on input shaft. Make sure bronze washer (18) is between the saw tooth plate (14) and the handwheel adapter (25). Install flat washer next (56), then the split lockwasher (32) and the acorn nut (41). Tighten acorn nut (41) onto the input shaft.
3. Attach the spinner knob (20) to the handwheel (24) using the preassembled hardware (45, 52, 57). Select the hole that is most comfortable for operation.

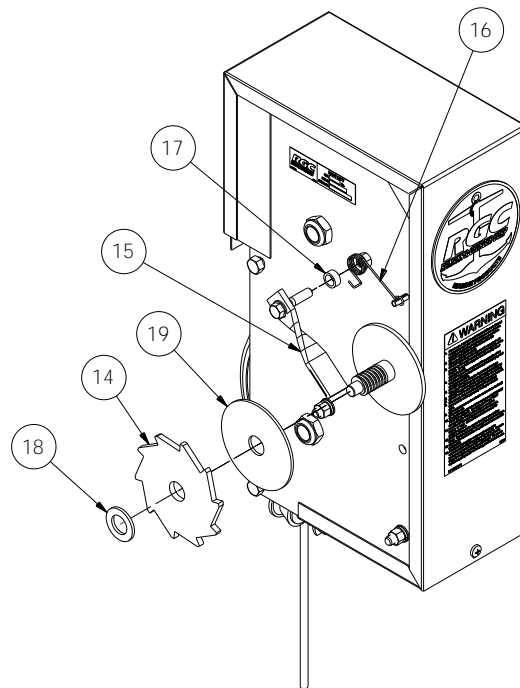
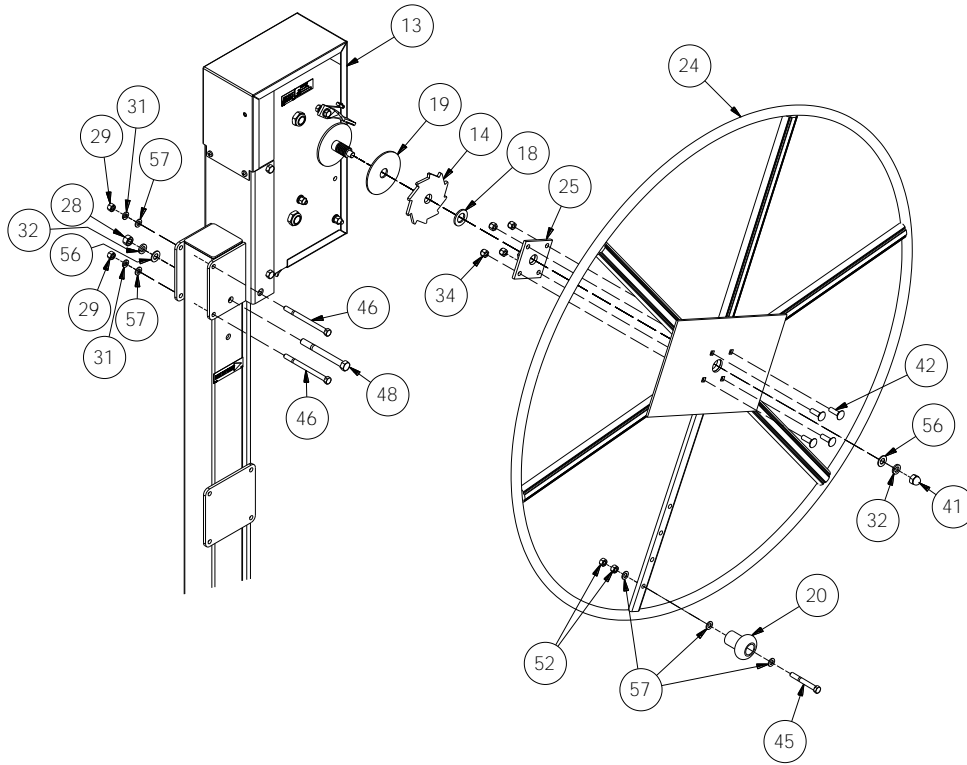

3.9.2. Winch Reeving

1. Remove the top and bottom guards from the winch housing by removing the (4) ¼ -20 pan head screws.
2. Position the winch drum so that the set screw faces at a 90° angle or perpendicular to, the vertical leg "A".
3. Starting from the bottom of winch, reeve the cut end of cable between the cable guide roller assembly, and up the backside of winch. Wrap the cable over the top of winch drum, inserting cable into the hole on the LEFT SIDE of drum. **Keep the cable flush with the drum wall.**



CAUTION:

DO NOT ALLOW END OF CABLE TO EXTEND OUT OF THE WINCH DRUM.

4. Secure the cable by tightening down the set screw using the Allen wrench included in the VL winch hardware bag.



WARNING:

WHEN REEVING THE WINCH, CLOCKWISE ROTATION OF THE HANDWHEEL MUST RAISE, NOT LOWER, THE PLATFORM. IF CLOCKWISE ROTATION OF THE HANDWHEEL LOWERS THE PLATFORM, YOU HAVE REEVED THE WINCH INCORRECTLY. AN UNCONTROLLED FREEWHEELING CAN BE TRIGGERED WITH THE WEIGHT OF A BOAT.

FREEWHEELING CAN CAUSE EQUIPMENT OR BOAT DAMAGE. HOWEVER, IF FREEWHEELING OCCURS, NEVER TRY TO STOP IT. THIS CAN CAUSE SERIOUS PERSONAL INJURY.

5. When wrapping the drum, do not allow any horizontal gaps in the cable winding.
6. When the winch reeving is done, the guards must be reinstalled. Do NOT operate the winch without the guards installed.
7. For Single Reeve: tighten down the nut to fasten the A-B load tube cable stud to leg B. Add and tighten a jam nut to the cable nut to lock the position.
8. For Double Reeve use the hardware shown (33, 35, 37, 38) to attach the A-B load tube cable to the winch.

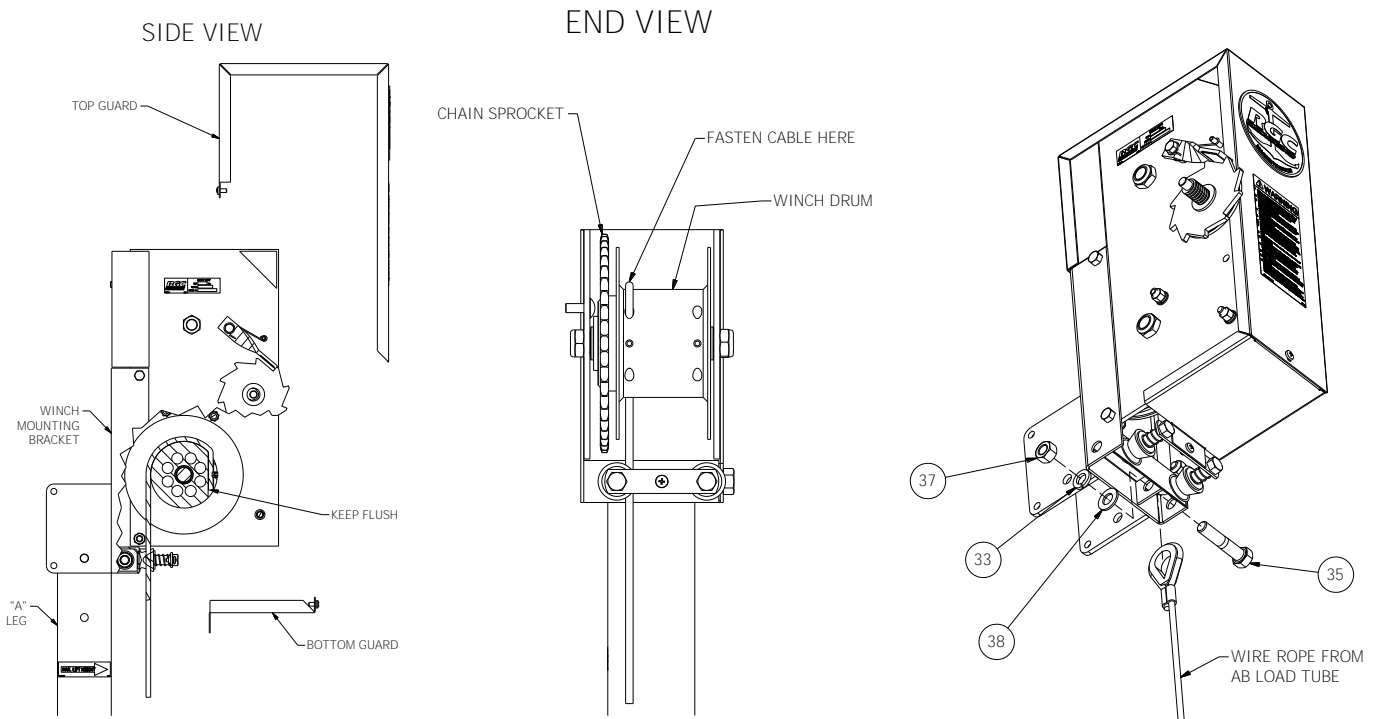

4. OPERATION

4.1. BEFORE OPERATING THE LIFT

1. Read and know the instructions and ensure that everyone understands the proper operating procedure.
2. When using a power drive, understand the use of all controls and connections provided with it.
3. Follow the Pre-Lifting Checklist before operating.
4. Do not use the lift if it shows any signs of damage.
5. Ensure that all bolts and nuts are fastened securely prior to operation.
6. Check that the winch is reeved properly. See reeving instructions in Chapter 3 of this manual.
7. Never try lifting anything other than a boat with this lift.



WARNING:

NEVER TRY TO USE THIS EQUIPMENT BEYOND ITS RATED CAPACITY. THIS CAN DAMAGE THE LIFT AND/OR BOAT RESULTING IN PERSONAL INJURY.

THE BOAT MUST BE PROPERLY POSITIONED ON THE LIFT BEFORE DOING ANY RAISING OR LOWERING. FAILURE TO DO THIS CAN CAUSE EQUIPMENT DAMAGE AND/OR PERSONAL INJURY.

8. Do not operate the lift under the influence of drugs, alcohol, or medication.
9. Completely remove any user or dealer installed locking devices.
10. Never try to lift or launch your boat in rough water conditions. This can damage your boat and/or the lift.

4.2. TESTING WINCH OPERATION

After the lift installation is complete, it is important that the winch functions properly. Test the winch operation as follows:

1. Raise the empty platform about one fourth the way up and release the handwheel. The handwheel or power drive must turn clockwise when raising the platform. The brake pawl must click, indicating that the brake is operative. An empty platform will have a normal tendency to slowly lower itself.



CAUTION:

IF YOU HAVE TO TURN THE HANDWHEEL COUNTERCLOCKWISE TO RAISE THE PLATFORM, YOU HAVE REEVED THE WINCH INCORRECTLY. YOU WILL IMMEDIATELY ENCOUNTER STRONG RESISTANCE WHICH CAN LEAD TO WINCH DAMAGE AND/OR WIRE ROPE BREAKAGE.

2. Repeat Step 1 in the half, three-quarters, and full lift positions.
3. Lower the empty platform to repeat steps 1 and 2 with your boat on the lift. The handwheel or power drive must turn counter-clockwise when lowering the platform. When loaded, the self-activating brake mechanism should stop the platform from lowering as soon as the operator stops turning the handwheel. Make sure this brake mechanism is operative.



WARNING:

IF THE HANDWHEEL STARTS TO FREELY SPIN DOWN FROM ANY LOADED TEST POSITION, NEVER TRY TO STOP IT. DO NOT USE A LIFT IN THIS CONDITION.

4. Contact your authorized dealer if the winch mechanism fails to perform as described in this section. Do NOT tamper with the winch mechanism.

4.3. RAISING AND LOWERING THE PLATFORM

1. Raise the platform by turning the handwheel clockwise. The self-activating brake mechanism will hold the platform at any desired height.
2. Platform should be raised a minimum of 1 foot between bottom of boat and highest potential water table height for your geographic area.
3. Lower the platform by turning the handwheel counterclockwise. Do not continue lowering the platform after the boat floats freely from the platform. Excessive winch wire rope slack may cause wire rope, lift, and winch damage.
4. Keep fingers and clothing clear of all moving parts. Keep people clear during operation of the lift.
5. Never allow people in the boat any time it is suspended above the water on the lift.



WARNING:

DO NOT STAND OR WALK ON THE LIFT PLATFORM WHILE IT IS IN ANY RAISED POSITION. THIS CAN CAUSE SERIOUS PERSONAL INJURY.

6. Check the lift periodically for frayed wire ropes and/or binding pulleys.
7. When using a power drive, avoid sudden stops.

4.4. SECURING LIFT WHEN NOT IN USE

At the end of operation, secure the lift to prevent unauthorized use. Proceed as follows:

1. Raise the platform to the desired height.
2. Padlock the handwheel to the post or lock out your power drive to prevent unauthorized use when your boat lift is unattended.

5. INSPECTION AND MAINTENANCE

5.1. GENERAL MAINTENANCE RULES

1. Do not allow persons other than authorized service personnel to repair this equipment.
2. If slings are used, inspect them for deterioration. Replace them immediately if they are worn.
3. Do not weld or otherwise modify the lift. Such alterations may weaken the structural integrity of the lift and invalidate your warranty.
4. Completely lower the lift before performing any type of maintenance or repair.



WARNING:

NEVER ALLOW ANYBODY TO WORK IN OR ON THE BOAT WHEN IT IS SUSPENDED ABOVE THE WATER ON THE LIFT. IF THE HANDWHEEL ON THE WINCH SHOULD START FREEWHEELING, SERIOUS INJURY OR DEATH COULD RESULT.

IF FREEWHEELING STARTS, NEVER TRY TO STOP IT. ALTHOUGH A SPIN DOWN OR "FREEWHEELING" CAN CAUSE LIFT OR BOAT DAMAGE, TRYING TO STOP FREEWHEELING CAN CAUSE SERIOUS PERSONAL INJURY.

5.2. WIRE ROPE INSPECTION PROCEDURE

Inspect the wire rope prior to each use for signs of wear, damage, or pinching. Inspect the entire wire rope working length. Thoroughly inspect the rope sections that pass over sheaves or drums, or that make opposing turns. Inspect wire rope and end attachments carefully. While inspecting, examine sheaves, guards, guides, drums, flanges, and other surfaces contacting wire rope during operation. Correct any condition harming the rope in use or other damage or worn surfaces at this time.



CAUTION:

WEAR HEAVY LEATHER GLOVES WHEN HANDLING WIRE ROPE. INSUFFICIENT HAND PROTECTION WHEN HANDLING WIRE ROPE CAN CAUSE PERSONAL INJURY.

Remove and immediately replace wire rope with one or more of the following defects:

1. Corrosion
2. Broken wires:
 - (a) One or more valley breaks. A valley break is a wire break occurring in the valley between two adjacent strands.
 - (b) Six randomly distributed broken wires in one rope lay. A rope lay is the length of rope along which one strand makes a complete revolution around the rope. See Figure 5-1. Keeping the rope clean and wound evenly on the winch drum will increase its life and efficiency.
3. Abrasion: Scrubbing, flattening or peening causing loss of more than one-third of the original diameter of the outside wires.
4. Kinking: Severe kinking, crushing, bird caging or other damage causing distortion of the rope structure. Bird caging is a bulging in the cable caused by the individual wires becoming untwisted. This untwisting of individual wires is usually caused by impact loading on the cable (such as a sudden stop).

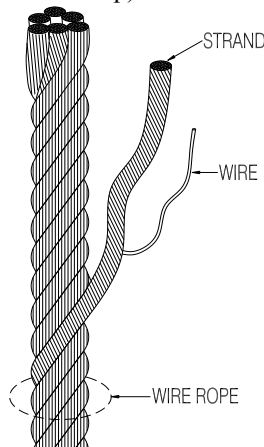

Wire Rope Components

5. Heat damage: Evidence of any heat damage caused by a torch or by contact with electrical wires.
6. Reduction of more than 1/64 inch from a nominal 5/16-inch or less diameter wire rope. Reduction of more than 1/32 inch from a nominal 3/8-inch to 1/2-inch diameter wire rope.

5.3. ANNUAL INSPECTION

At least once a year, the lift must be thoroughly inspected using the following procedure.



WARNING:

DO NOT ALLOW ANYBODY TO USE THE LIFT UNTIL THIS MAINTENANCE IS COMPLETED.

1. Tighten all bolts.
2. Check the sheaves to ensure that they spin freely. If they bind, replace them immediately.
3. Check frame thoroughly for defects.
4. Perform the winch maintenance as described in Section 5.4.

5.4. ANNUAL WINCH MAINTENANCE

1. The winch maintenance schedule must be followed to avoid possible equipment failure or personal injury.
2. Before removing the winch cover to inspect or work on the winch, be sure the platform is completely lowered. Do not reach through the wheel and manipulate any of the winch mechanisms when the platform is raised.
3. Grease the chains and bearing inside winch.
4. Grease wire ropes and sheave bearings.
5. Grease winch hub.
6. Remove acorn nut on handwheel and turn counterclockwise to remove wheel to clearly expose the input shaft threads.
7. Grease threads; avoid contaminating fibrous brake disk.
8. Thread wheel back on until brake pawl begins clicking. Reinstall and tighten acorn nut.



WARNING:

AFTER EVERY WINCH MAINTENANCE, TEST THE WINCH MECHANISM AS DESCRIBED IN CHAPTER 4 BEFORE LETTING ANYONE USE THE LIFT.

5.5. STORAGE PROCEDURE



CAUTION:

DO NOT STORE THE LIFT IN THE WATERWAY IF FREEZING TEMPERATURES ARE EXPECTED. THIS WILL CAUSE EQUIPMENT DAMAGE.

1. Position boat on platform so the lower unit of the motor is against the optional motor stop (if used).
2. A boat that has water in it from a rainstorm could exceed the recommended weight capacity for the lift. Just 1 gallon of water weighs over 8 pounds. Be sure to remove the plug while the boat is up on the lift. Make sure you replace the plug prior to launching your boat.
3. Protect your lift as far as possible from damage caused by environmental factors such as airborne fallout, chemicals, tree sap, and weather hazards.
4. Never use the lift to hang or store any auxiliary equipment such as boating hardware.
5. Do not allow anyone to swim or play near the lift at any time.
6. Padlock the handwheel to the post and disconnect the power to any electric motor when your boat lift is unattended. Never assume you will find the lift in the same condition that you left it.

6. TROUBLESHOOTING

The following chart is intended to assist with troubleshooting your vertical lift. While not all inclusive, the chart outlines the most common causes of a problem and the recommended course of action.

| SYMPTOM | CAUSE AND CORRECTIVE ACTION |
|--|--|
| Winch resists platform raising. | <p>Winch has been reeved incorrectly – winch must turn clockwise to raise platform. See Section 3.9.</p> <p>Sheaves binding – inspect/lubricate/replace.</p> <p>Winch wire rope is rubbing against the winch frame – repeat winch reeving if necessary following Section 3.9.</p> |
| Winch fails to hold the platform in a given position as describe in the test procedure of Section 4.2. | <p>Contact your authorized dealer – tampering with the winch mechanism can cause equipment damage that may invalidate your warranty.</p> |
| Winch is operating properly, but platform raising is either difficult or impossible. | <p>Platform is binding because frame is either not square or not set level in the water – refer to Sections 3.6 and 3.7.</p> <p>One or more wires in wire rope are broken – refer to Section 5.2</p> <p>Sheaves binding – inspect/lubricate/replace.</p> <p>One or more wire ropes are excessively worn – replace as required and follow monthly wire rope inspection procedure described in Section 5.2.</p> <p>User or dealer installed locking devices are in place – remove locking devices.</p> <p>Auxiliary equipment such as boating hardware is being improperly hung on the lift – remove this equipment permanently.</p> |
| Boat is not lifting level – stern is lifting higher or lower than bow. | <p>Frame is not level in the water – relocate pin connections between the adjustable and vertical legs.</p> <p>Frame is level in the water but spreader tube wire ropes are not tight enough –</p> <ol style="list-style-type: none"> 1. Tighten down wire rope stud nut to add tension to the B-C spreader tube wire rope. 2. Tighten down the wire rope stud nut to add tension to the A-D spreader tube wire ropes. Check that the B-C and A-D spreader wire ropes are equal in tension and that the platform is level. |
| Boat shifts position when operating the lift. | <p>Boat is not properly secured on the lift – failure to properly secure boat can cause equipment damage and/or serious personal injury.</p> |
| Lowering operation triggers a “freewheeling” of the handwheel. | <p>Winch has been reeved incorrectly – winch must turn counter-clockwise to lower the platform. See Section 3.9</p> <p>Unauthorized brake pawl release has occurred – do not try to correct this yourself. Contact your authorized dealer immediately.</p> |
| Lowest platform position too high or low relative to the water. | <p>Connections between the vertical and adjustable legs need readjusting – do this with Item 26 leg pin shown in Figure 3-3.</p> |
| Boat is getting damaged during raising or lowering operations. | <p>One or more bolts are installed improperly – all bolts must be installed from the inside of the lift.</p> |

7. PARTS LISTS

Each reference number in the following parts lists can be matched with the reference number referred to in both the text and illustrations of Chapter 3, Installation and Setup.

7.1. LIFTS

| Lift Model | Lift P/N | Bundle 1 | Bundle 2 | Bundle 3 | Hardware Carton of Parts | R18 w/MTG Hardware |
|------------|----------|----------|----------|----------|--------------------------|--------------------|
| VLS60124 | 3654495 | 3654509 | 3654515 | 3651247 | 3653503 | 3704300 |
| VLS60124T | 3654496 | 3654510 | 3654516 | 3657243 | 3653503 | 3704300 |
| VLS80124T | 3654499 | 3654513 | 3654517 | 3688112 | 3653505 | 3704300 |
| VLS100132T | 3654500 | 3654514 | 3654518 | 3610155 | 3653506 | 3704400 |

7.2. BUNDLES

7.2.1. VLS60124 BUNDLE 1 OF 3 - 3654509

| REF. | PART NUMBER | QTY | DESCRIPTION |
|------|-------------|-----|-------------|
| 1 | 3654473 | 1 | A-LEG |
| 2 | 3654479 | 1 | B-LEG |
| 3 | 3654462 | 1 | C-LEG |
| 4 | 3654485 | 1 | D-LEG |
| 5 | 4107537 | 4 | FOOT PLATE |

7.2.2. VLS60124T BUNDLE 1 OF 3 - 3654510

| REF. | PART NUMBER | QTY | DESCRIPTION |
|------|-------------|-----|-------------|
| 1 | 3654474 | 1 | A-LEG |
| 2 | 3654480 | 1 | B-LEG |
| 3 | 3654463 | 1 | C-LEG |
| 4 | 3654486 | 1 | D-LEG |
| 5 | 4107537 | 4 | FOOT PLATE |

7.2.3. VLS80124T BUNDLE 1 OF 3 - 3654513

| REF. | PART NUMBER | QTY | DESCRIPTION |
|------|-------------|-----|-------------|
| 1 | 3654474 | 1 | A-LEG |
| 2 | 3654481 | 1 | B-LEG |
| 3 | 3654464 | 1 | C-LEG |
| 4 | 3654487 | 1 | D-LEG |
| 5 | 4107537 | 4 | FOOT PLATE |

7.2.4. VLS100132T BUNDLE 1 OF 3 - 3654514

| REF. | PART NUMBER | QTY | DESCRIPTION |
|------|-------------|-----|-------------|
| 1 | 3654475 | 1 | A-LEG |
| 2 | 3654476 | 1 | B-LEG |
| 3 | 3654461 | 1 | C-LEG |
| 4 | 3654488 | 1 | D-LEG |
| 5 | 4107537 | 4 | FOOT PLATE |

7.2.5. VLS60124 BUNDLE 2 OF 3 - 3654515

| REF. | PART NUMBER | QTY | DESCRIPTION |
|------|-------------|-----|-----------------|
| 6 | 3654459 | 1 | SIDE HORIZONTAL |
| 7 | 3654457 | 1 | END HORIZONTAL |
| 8 | 3605938 | 1 | AD SPREADER |
| 9 | 3605939 | 1 | BC SPREADER |

7.2.6. VLS60124T BUNDLE 2 OF 3 - 3654516

| REF. | PART NUMBER | QTY | DESCRIPTION |
|------|-------------|-----|-----------------|
| 6 | 3654459 | 1 | SIDE HORIZONTAL |
| 7 | 3654457 | 1 | END HORIZONTAL |
| 8 | 3605725 | 1 | AD SPREADER |
| 9 | 3605726 | 1 | BC SPREADER |

7.2.7. VLS80124T BUNDLE 2 OF 3 - 3654517

| REF. | PART NUMBER | QTY | DESCRIPTION |
|------|-------------|-----|-----------------|
| 6 | 3654459 | 1 | SIDE HORIZONTAL |
| 7 | 3654457 | 1 | END HORIZONTAL |
| 8 | 3606725 | 1 | AD SPREADER |
| 9 | 3606726 | 1 | BC SPREADER |

7.2.8. VLS100132T BUNDLE 2 OF 3 - 3654518

| REF. | PART NUMBER | QTY | DESCRIPTION |
|------|-------------|-----|-----------------|
| 6 | 3654460 | 1 | SIDE HORIZONTAL |
| 7 | 3654456 | 1 | END HORIZONTAL |
| 8 | 3610350 | 1 | AD SPREADER |
| 9 | 3610355 | 1 | BC SPREADER |

7.2.9. VLS60124 BUNDLE 3 OF 3 - 3651247

| REF. | PART NUMBER | QTY | DESCRIPTION |
|------|-------------|-----|--------------|
| 10 | 3605904 | 1 | AB LOAD TUBE |
| 11 | 3605924 | 1 | CD LOAD TUBE |

7.2.10. VLS60124T BUNDLE 3 OF 3 - 3657243

| REF. | PART NUMBER | QTY | DESCRIPTION |
|------|-------------|-----|--------------|
| 10 | 3605727 | 1 | AB LOAD TUBE |
| 11 | 3605728 | 1 | CD LOAD TUBE |

7.2.11. VLS80124T BUNDLE 3 OF 3 - 3688112

| REF. | PART NUMBER | QTY | DESCRIPTION |
|------|-------------|-----|--------------|
| 10 | 3688205 | 1 | AB LOAD TUBE |
| 11 | 3606727 | 1 | CD LOAD TUBE |

7.2.12. VLS100132T BUNDLE 3 OF 3 - 3610155

| REF. | PART NUMBER | QTY | DESCRIPTION |
|------|-------------|-----|--------------|
| 10 | 3610340 | 1 | AB LOAD TUBE |
| 11 | 3610345 | 1 | CD LOAD TUBE |

7.2.13. VLS60124, VLS60124T & VLS80124T WINCH & WINCH HARDWARE - 3704300

| REF. | PART NUMBER | QTY | DESCRIPTION |
|------|----------------|----------|---|
| 13 | 3704300 | 1 | R18LT WINCH |
| 14 | 3701501 | 1 | R18LT BRAKE RATCHET - 10 TOOTH |
| 15 | 3709047 | 1 | R18LT PAWL ASSEMBLY |
| 16 | 5805936 | 1 | R18LT PAWL SPRING |
| 17 | 3709038 | 1 | R18LT PAWL SPACER |
| 18 | 5100601 | 1 | 7/8" ID BRONZE THRUST BEARING |
| 19 | 6703833 | 1 | 4" OD BRAKE DISC |
| | 3755201 | 1 | R18LT MOUNTING HARDWARE BAG OF BOLTS – includes: |
| 28 | 5803612 | 1 | 1/2-13 NUT SILICON BRONZE |
| 29 | 5803638 | 2 | 3/8-16 NUT SILICON BRONZE |
| 30 | 5806187 | 1 | 3/16 ALLEN WRENCH |
| 31 | 5806243 | 2 | 3/8 WASHER SPLIT LOCK SS |
| 32 | 5806244 | 1 | 1/2 WASHER SPLIT LOCK SS |
| 46 | 5896263 | 2 | 3/8-16 X 5 HEX BOLT SS |
| 48 | 5896294 | 1 | 1/2-13 x 5 HEX BOLT SS |
| 56 | 5896400 | 1 | 1/2" WASHER FLAT SS |
| 57 | 5896406 | 2 | 3/8" WASHER FLAT SS |

7.2.14. VLS100132T WINCH & WINCH HARDWARE - 3704400

| REF. | PART NUMBER | QTY | DESCRIPTION |
|-------|----------------|----------|---|
| 13 | 3704400 | 1 | R18HD WINCH |
| 14 | 3701501 | 1 | R18LT BRAKE RATCHET - 10 TOOTH |
| 15 | 3709047 | 1 | R18LT PAWL ASSEMBLY |
| 16 | 5805936 | 1 | R18LT PAWL SPRING |
| 17 | 3709038 | 1 | R18LT PAWL SPACER |
| 18 | 5100601 | 1 | 7/8" ID BRONZE THRUST BEARING |
| 19 | 6703833 | 1 | 4" OD BRAKE DISC |
| | 3710408 | 1 | R18HD MOUNTING HARDWARE BAG OF BOLTS – includes: |
| 28/29 | 5803612 | 3 | 1/2-13 NUT SILICON BRONZE |
| 30 | 5806187 | 3 | 3/16 ALLEN WRENCH |
| 31/32 | 5806244 | 3 | 1/2 WASHER SPLIT LOCK SS |
| 46/48 | 5896294 | 3 | 1/2-13 x 5 HEX BOLT SS |
| 56/57 | 5896400 | 3 | 1/2" WASHER FLAT SS |

7.2.15. VLS60124 & VLS60124T - HARDWARE CARTON OF PARTS - 3653503

| REF. | PART NUMBER | QTY | DESCRIPTION |
|-------|----------------|----------|---|
| | 3653486 | 4 | CORNER HARDWARE BAG OF BOLTS – includes: |
| 34 | 5840103 | 15 | 3/8-16 NUT NYLOCK ALUMINUM |
| 43 | 5896247 | 12 | 3/8-16 X 1 HEX BOLT SS |
| 44 | 5896248 | 3 | 3/8-16 X 1-1/4 HEX BOLT SS |
| 47 | 5896292 | 1 | 1/2-13 X 4 HEX BOLT SS |
| 59 | 5897018 | 1 | 1/2-13 NUT NYLOCK SS |
| | 3653496 | 1 | CAP BAG - includes |
| 61 | 6403794 | 4 | BLACK CAP 2" X 4" |
| 60 | 6403750 | 3 | BLACK CAP 3.5" X 3.5" |
| | 3653490 | 1 | CABLE HARDWARE BAG OF BOLTS – includes: |
| 33 | 5806246 | 5 | 5/8" WASHER SPLIT LOCK |
| 35 | 5896305 | 1 | 5/8-11 X 3 HEX BOLT SS |
| 36 | 5896306 | 4 | 5/8-11 X 3-1/2 HEX BOLT SS |
| 37 | 5896380 | 5 | 5/8-11 NUT SS |
| 54/55 | 5896397 | 8 | 9/16-12 NUT SS |
| 38 | 5896414 | 5 | 5/8" WASHER FLAT SS |
| | 4100900 | 1 | LEG PIN BAG – includes: |
| 26 | 4100505 | 4 | LEG PIN 4" |
| 40 | 5893781 | 4 | HAIRPIN COTTOR PIN |

7.2.16. VLS80124T - HARDWARE CARTON OF PARTS - 3653505

| REF. | PART NUMBER | QTY | DESCRIPTION |
|------|----------------|----------|---|
| | 3653485 | 4 | CORNER HARDWARE BAG OF BOLTS – includes: |
| 34 | 5840103 | 16 | 3/8-16 NUT NYLOCK ALUMINUM |
| 43 | 5896247 | 12 | 3/8-16 X 1 HEX BOLT SS |
| 44 | 5896248 | 4 | 3/8-16 X 1-1/4 HEX BOLT SS |
| 47 | 5896292 | 1 | 1/2-13 X 4 HEX BOLT SS |
| 59 | 5897018 | 1 | 1/2-13 NUT NYLOCK SS |
| | 3653496 | 1 | CAP BAG - includes |
| 61 | 6403794 | 4 | BLACK CAP 2" X 4" |
| 60 | 6403750 | 3 | BLACK CAP 3.5" X 3.5" |
| | 3653490 | 1 | CABLE HARDWARE BAG OF BOLTS – includes: |
| 33 | 5806246 | 5 | 5/8" WASHER SPLIT LOCK |
| 35 | 5896305 | 1 | 5/8-11 X 3 HEX BOLT SS |
| 36 | 5896306 | 4 | 5/8-11 X 3-1/2 HEX BOLT SS |
| 37 | 5896380 | 5 | 5/8-11 NUT SS |
| 54 | 5896381 | 4 | 3/4-10 NUT SS |
| 55 | 5896397 | 4 | 9/16-12 NUT SS |
| 38 | 5896414 | 5 | 5/8" WASHER FLAT SS |
| | 4100900 | 4 | LEG PIN BAG – includes: |
| 26 | 4100505 | 4 | LEG PIN 4" |
| 40 | 5893781 | 4 | HAIRPIN COTTOR PIN |

7.2.17. VLS100132T - HARDWARE CARTON OF PARTS - 3653506

| REF. | PART NUMBER | QTY | DESCRIPTION |
|-------|----------------|----------|---|
| | 3653487 | 4 | CORNER HARDWARE BAG OF BOLTS – includes: |
| 34 | 5840103 | 20 | 3/8-16 NUT NYLOCK ALUMINUM |
| 43 | 5896247 | 16 | 3/8-16 X 1 HEX BOLT SS |
| 44 | 5896248 | 4 | 3/8-16 X 1-1/4 HEX BOLT SS |
| 47 | 5896292 | 1 | 1/2-13 X 4 HEX BOLT SS |
| 59 | 5897018 | 1 | 1/2-13 NUT NYLOCK SS |
| | 3653497 | 1 | CAP BAG - includes |
| 61 | 6403794 | 8 | BLACK CAP 2" X 4" |
| 60 | 6403750 | 3 | BLACK CAP 3.5" X 3.5" |
| | 3653492 | 1 | CABLE HARDWARE BAG OF BOLTS – includes: |
| 35 | 5893611 | 1 | 7/8-9 X 2-1/2 HEX BOLT SS |
| 36 | 5893612 | 4 | 7/8-9 X 3-1/2 HEX BOLT SS |
| 37 | 5893620 | 5 | 7/8-9 NUT SS |
| 38 | 5893625 | 5 | 7/8" WASHER FLAT SS |
| 33 | 5893630 | 5 | 7/8" WASHER SPLIT LOCK SS |
| 54/55 | 5896381 | 8 | 3/4-10 NUT SS |
| | 4100900 | 1 | LEG PIN BAG – includes: |
| 26 | 4100505 | 4 | LEG PIN 4" |
| 40 | 5893781 | 4 | HAIRPIN COTTOR PIN |

7.2.18. VL HANDWHEEL 4' CARTON - 3703812

| REF. | PART NUMBER | QTY | DESCRIPTION |
|------|----------------|----------|--|
| 24 | 3703803 | 1 | VL HANDWHEEL 4' |
| | 3703800 | 1 | HANDWHEEL MOUNTING BAG OF BOLTS R18 |
| 42 | 5896217 | 4 | 3/8-16 X 1-1/4 CARRIAGE BOLT SS |
| 34 | 5840103 | 4 | 3/8-16 NUT NYLOCK ALUMINUM |
| 56 | 5896400 | 1 | 1/2" WASHER FLAT SS |
| 41 | 5896192 | 1 | 1/2-20 ACORN NUT SS |
| 32 | 5806244 | 1 | 1/2" WASHER SPLIT LOCK SS |
| 25 | 3709007 | 1 | R18 HANDWHEEL ADAPTOR |
| | 3671010 | 1 | HANDWHEEL SPINNER KNOB ASSEMBLY SS |
| 57 | 5896406 | 3 | 3/8" WASHER FLAT SS |
| 45 | 5896255 | 1 | 3/8-16 X 3 HEX BOLT SS |
| 52 | 5896377 | 2 | 3/8-16 NUT SS |
| 20 | 3603670 | 1 | HANDWHEEL SPINNER KNOB |

LIMITED PRODUCT WARRANTY

Reimann & Georger Corporation

Marine Products

RGC Marine products, hereafter referred to as the “Manufacturer”, extends this limited warranty to the original purchaser of this product. The original purchaser, hereinafter referred to as the “Buyer”, is defined as the first legal owner of this product other than an authorized distributor or dealer who has bought the product from the Manufacturer for resale to the public. **The Buyer must complete and return the Warranty Registration section of the provided Warranty Card to make this limited warranty effective.**

CONSUMER PRODUCT PROVISIONS

I. ARTICLE I—CONSUMER PRODUCT PROVISIONS: THE FOLLOWING PROVISIONS SHALL BE APPLICABLE IF THIS PRODUCT IS BEING PURCHASED FOR PERSONAL, FAMILY OR HOUSEHOLD PURPOSES.

THE CONSUMER PRODUCT PROVISIONS CONTAINED IN THIS ARTICLE I SHALL APPLY UNLESS THIS PRODUCT IS BEING PURCHASED SOLELY FOR COMMERCIAL OR INDUSTRIAL USE, IN WHICH EVENT THE PROVISIONS CONTAINED IN ARTICLE II BELOW SHALL APPLY AND THE PROVISIONS CONTAINED IN THIS ARTICLE I SHALL BE INAPPLICABLE.

A. 2-YEAR LIMITED WARRANTY

The Manufacturer warrants to the Buyer that all supplied parts shall be free of defects in material and workmanship for a period of two (2) years from date of original purchase. This limited warranty covers the cost of all parts and labor needed to repair any item that is found to be defective in material and workmanship. Items covered include cables, sheaves, chains, motors, reducers, switches, control panels and ground fault circuit interrupters.

B. 15-YEAR LIMITED WARRANTY ON VL/PL SERIES ALUMINUM FRAME EXTRUSION

The Manufacturer warrants to the Buyer that the frame and extrusions shall be free of defects in material and workmanship for a period of fifteen (15) years from date of original purchase. This limited warranty covers the cost of all parts and labor needed to repair any item that is found to be defective in material and workmanship.

C. MANUFACTURER’S OBLIGATIONS

The Manufacturer’s sole obligation under either of these limited warranties is the replacement or repair, at the Manufacturer’s discretion, of parts found to be defective.

D. NO SPECIAL, INCIDENTAL OR CONSEQUENTIAL DAMAGES

IN NO EVENT SHALL THE MANUFACTURER BE LIABLE TO THE BUYER OR ANY PERSON FOR ANY INDIRECT, SPECIAL, INCIDENTAL, OR CONSEQUENTIAL LOSSES OR DAMAGES CONNECTED WITH THE USE OF THE PRODUCT UNDER WARRANTY. SUCH DAMAGES FOR WHICH THE MANUFACTURER SHALL NOT BE RESPONSIBLE INCLUDE, BUT ARE NOT LIMITED TO, LOST TIME AND CONVENIENCE, LOSS OF USE OF THE PRODUCT, THE COST OF A PRODUCT RENTAL, COSTS OF GASOLINE, TELEPHONE, TRAVEL, OR LODGING, THE LOSS OF PERSONAL OR COMMERCIAL PROPERTY, AND THE LOSS OF REVENUE.

Some States do not allow the exclusion or limitation of incidental or consequential damages, so the above limitation or exclusion may not apply to you.

E. NO LIABILITY IN EXCESS OF PURCHASE PRICE

IN NO EVENT SHALL THE MANUFACTURER’S OBLIGATIONS UNDER THIS LIMITED WARRANTY EXCEED THE PURCHASE PRICE OF THE PRODUCT.

F. NO EXTENSION OF STATUTE OF LIMITATIONS

ANY REPAIRS PERFORMED UNDER EITHER OF THESE WARRANTIES SHALL NOT IN ANY WAY EXTEND THE TWO-YEAR AND FIFTEEN-YEAR STATUTES OF LIMITATIONS CONTAINED IN THIS LIMITED WARRANTY.

G. PROCEDURE FOR WARRANTY PERFORMANCE

If the product fails to perform to the Manufacturer's specifications, the Buyer must contact the dealer from whom the product was purchased. The Buyer must provide the dealer with the applicable model and serial numbers, the date of purchase, and the nature of the problem.

H. PREAPPROVAL OF LABOR COSTS

All labor costs related to a dealer's performance of the warranty obligations under this limited warranty must be pre-approved by Reimann & Georger Corp. Marine Products.

I. NO OTHER EXPRESS WARRANTIES

THE MANUFACTURER IS NOT SUBJECT TO ANY EXPRESS WARRANTIES OTHER THAN THOSE SET FORTH ABOVE.

J. LIMIT ON DURATION OF IMPLIED WARRANTIES

THE DURATION OF ANY IMPLIED WARRANTIES UNDER APPLICABLE STATE LAW RELATING TO THE PURCHASE OF THIS PRODUCT SHALL BE LIMITED TO A PERIOD OF TWO (2) YEARS FROM THE DATE OF PURCHASE.

Some States do not allow limitations on how long an implied warranty lasts, so the above limitations may not apply to you.

K. QUESTIONS REGARDING LIMITED WARRANTY

Any questions regarding this limited warranty or the procedure which the consumer should follow in order to obtain performance of any warranty obligation may be addressed to either the dealer from whom this product is purchased or to Reimann & Georger Corp. Marine Products, 1849 Harlem Road, Buffalo, NY 14212.

L. EXCLUSIONS FROM LIMITED WARRANTY. THIS LIMITED WARRANTY DOES NOT COVER ANY OF THE FOLLOWING:

1. Equipment which has been abused, damaged, used beyond rated capacity, or which is damaged or has defects caused by repairs or service completed by persons other than authorized service personnel.
2. Costs of repairing damage caused by environmental factors which include, but are not limited to, airborne fallout, chemicals, tree sap, salt, ocean spray, and water hazards.
3. Damage caused by acts of God which include, but are not limited to, hailstorms, windstorms, tornadoes, sandstorms, lightning, floods, and earthquakes.
4. Damage under conditions caused by fire or accident, by abuse or negligence, by improper installation, by misuse, by incorrect operation, by "normal wear and tear", by improper adjustment or alteration, by alterations not done by the Manufacturer, or by failure of product parts from such alterations.
5. Costs of repairing damage caused by poor or improper maintenance, costs of normally scheduled maintenance, or the cost of replacing any parts unless done as the result of a repair covered by your two-year limited warranty.
6. Costs of modifying the product in any way once delivered to the Buyer, even if such modifications were added as a production change on other products made after the Buyer's product was built.

M. RIGHT TO MODIFY PRODUCT

The Manufacturer has the right to modify this product at any time without incurring any obligation to make the same or similar modifications on products previously purchased.

N. NO AUTHORITY TO ALTER WARRANTY

No agent, representative, distributor or dealer has any authority to alter the terms of this warranty in any way.

O. SPECIFIC LEGAL RIGHTS

This warranty gives you specific legal rights and you may also have other rights which vary from State to State.

COMMERCIAL PRODUCT PROVISIONS

II. ARTICLE II—COMMERCIAL PRODUCT PROVISIONS: THE FOLLOWING PROVISIONS SHALL BE APPLICABLE ONLY IF THIS PRODUCT IS BEING PURCHASED SOLELY FOR COMMERCIAL OR INDUSTRIAL USE. IF THIS PRODUCT IS BEING PURCHASED FOR PERSONAL, FAMILY OR HOUSEHOLD PURPOSES, THE PROVISIONS CONTAINED IN THIS ARTICLE II SHALL NOT BE APPLICABLE AND THE PROVISIONS CONTAINED IN ARTICLE I ABOVE SHALL APPLY.

A. 1-YEAR LIMITED WARRANTY

The Manufacturer warrants to the Buyer that all supplied parts shall be free of defects in material and workmanship for a period of one (1) year from date of original purchase. This limited warranty covers the cost of all parts and labor needed to repair any item that is found to be defective in material and workmanship. Items covered include cables, sheaves, chains, motors, reducers, switches, control panels and ground fault circuit interrupters.

B. 5-YEAR LIMITED WARRANTY ON VL/PL SERIES ALUMINUM FRAME EXTRUSION

The Manufacturer warrants to the Buyer that the frame and extrusions shall be free of defects in material and workmanship for a period of five (5) years from date of original purchase. This limited warranty covers the cost of all parts and labor needed to repair any item that is found to be defective in material and workmanship.

C. MANUFACTURER'S OBLIGATIONS

The Manufacturer's sole obligation under either of these limited warranties is the replacement or repair, at the Manufacturer's discretion, of parts found to be defective.

D. NO SPECIAL, INCIDENTAL, OR CONSEQUENTIAL DAMAGES

IN NO EVENT SHALL THE MANUFACTURER BE LIABLE TO THE BUYER OR ANY PERSON FOR ANY INDIRECT, SPECIAL, INCIDENTAL, OR CONSEQUENTIAL LOSSES OR DAMAGES CONNECTED WITH THE USE OF THE PRODUCT UNDER WARRANTY. SUCH DAMAGES FOR WHICH THE MANUFACTURER SHALL NOT BE RESPONSIBLE INCLUDE, BUT ARE NOT LIMITED TO, LOST TIME AND CONVENIENCE, LOSS OF USE OF THE PRODUCT, THE COST OF A PRODUCT RENTAL, COSTS OF GASOLINE, TELEPHONE, TRAVEL, OR LODGING, THE LOSS OF PERSONAL OR COMMERCIAL PROPERTY, AND THE LOSS OF REVENUE.

E. NO LIABILITY IN EXCESS OF PURCHASE PRICE

IN NO EVENT SHALL THE MANUFACTURER'S OBLIGATIONS UNDER THIS LIMITED WARRANTY EXCEED THE PURCHASE PRICE OF THE PRODUCT.

F. NO EXTENSION OF STATUTE OF LIMITATIONS

ANY REPAIRS PERFORMED UNDER EITHER OF THESE WARRANTIES SHALL NOT IN ANY WAY EXTEND THE RESPECTIVE STATUTES OF LIMITATIONS CONTAINED IN THIS LIMITED WARRANTY.

G. WAIVER OF OTHER WARRANTIES

THESE EXPRESS WARRANTIES ARE IN LIEU OF AND EXCLUDE ANY AND ALL OTHER WARRANTIES, EXPRESS OR IMPLIED, INCLUDING, BUT NOT LIMITED TO, THE IMPLIED WARRANTIES OR MERCHANTABILITY AND FITNESS FOR A PARTICULAR PURPOSE.

H. PROCEDURE FOR WARRANTY PERFORMANCE

If the product fails to perform to the Manufacturer's specifications, the Buyer must contact the dealer from whom the product was purchased. The Buyer must provide the dealer with the applicable model and serial numbers, the date of purchase, and the nature of the problem.

I. PREAPPROVAL OF LABOR COSTS

All labor costs related to a dealer's performance of the warranty obligations under this limited warranty must be pre-approved by Reimann & Georger Corp. Marine Products.

J. EXCLUSIONS FROM WARRANTY. THIS LIMITED WARRANTY DOES NOT COVER ANY OF THE FOLLOWING:

1. Equipment which has been abused, damaged, used beyond rated capacity, or which is damaged or has defects caused by repairs or service completed by persons other than authorized service personnel.
2. Costs of repairing damage caused by environmental factors which include, but are not limited to, airborne fallout, chemicals, tree sap, salt, ocean spray, and water hazards.
3. Damage caused by acts of God which include, but are not limited to, hailstorms, windstorms, tornadoes, sandstorms, lightning, floods, and earthquakes.
4. Damage under conditions caused by fire or accident, by abuse or negligence, by improper installation, by misuse, by incorrect operation, by "normal wear and tear", by improper adjustment or alteration, by alterations not done by the Manufacturer, or by failure of product parts from such alterations.
5. Costs of repairing damage caused by poor or improper maintenance, costs of normally scheduled maintenance, or the cost of replacing any parts unless done as the result of a repair covered by your one-year limited warranty.
6. Costs of modifying the product in any way once delivered to the Buyer, even if such modifications were added as a production change on other products made after the Buyer's product was built.

K. RIGHT TO MODIFY PRODUCT

The Manufacturer has the right to modify this product at any time without incurring any obligation to make the same or similar modifications on products previously purchased.

L. NO AUTHORITY TO ALTER WARRANTY

No agent, representative, distributor, or dealer has any authority to alter the terms of this warranty in any way.

M. SPECIFIC LEGAL RIGHTS

This warranty gives you specific legal rights, and you may also have other rights which vary from State to State.