

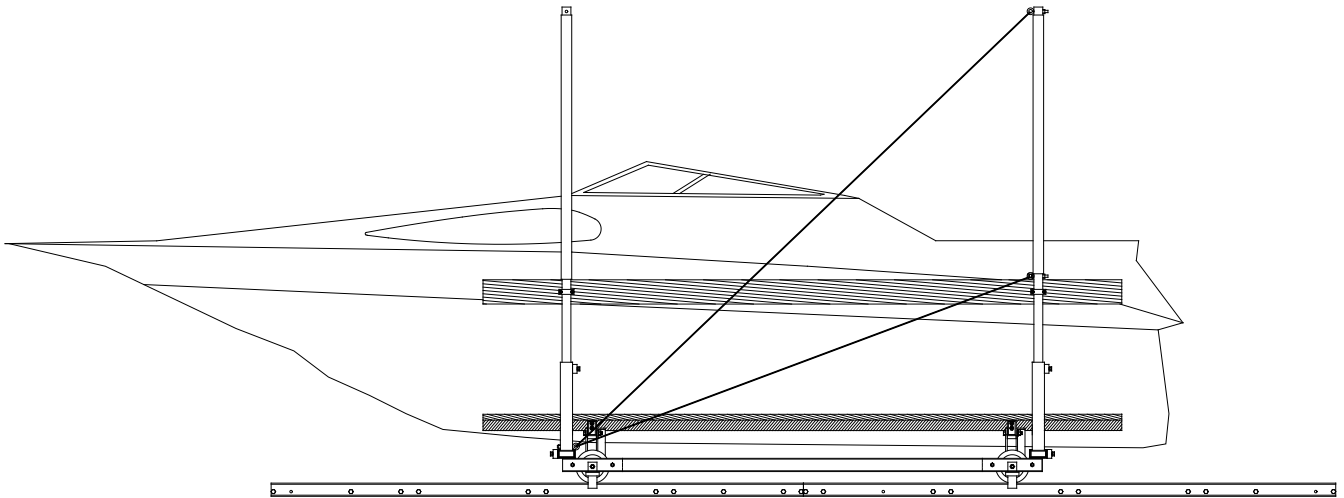

AR6000 BEACHER RAILWAY INSTRUCTIONS



REIMANN & GEORGER CORPORATION
MARINE PRODUCTS
P/N 6112093

BUFFALO, NY
08/25/15

TABLE OF CONTENTS

CHAPTER	TITLE	PAGE
1	SAFETY	1
1.1	Introduction	1
1.2	Safety Definitions	1
1.3	Equipment Safety Labels	1
1.4	Equipment and Personnel Safety	1
1.5	Installation Safety	2
1.6	Operating Safety	2
1.6.1	General Safety	2
1.6.2	Safety When Raising the Boat	3
1.6.3	Safety When Lowering the Boat	3
1.7	Maintenance and Storage safety	3
2	SPECIFICATIONS	4
2.1	Technical Data	4
2.2	Nameplate and Serial Number Tag	4
2.3	Optional Equipment	5
3	INSTALLATION AND SETUP	6
3.1	Pre-Installation Checks	6
3.2	Track and Truck Assembly	6
3.3	Truck / Carriage Assembly	8
3.4	Carriage Bunk Assembly	8
3.5	Carriage Guide On Assembly	9
3.6	Adjusting Bunks and Guide Ons	11
3.7	Positioning the Track	12
3.8	Securing the Boat on the Carriage	12
3.9	Final Assembly Checklist	13
4	OPERATION.....	14
4.1	Before Operating the Beacher	14
4.2	Testing Power Drive Operation	14
4.3	Raising and Lowering the Carriage	15
4.4	Securing Beacher When Not in Use	15
5	INSPECTION AND MAINTENANCE	16
5.1	General Maintenance Rules	16
5.2	Wire Rope Inspection Procedure	16
5.3	Annual Inspection	17
5.4	Annual Power Drive Maintenance	17
5.5	Storage Procedure	18
6	TROUBLESHOOTING.....	19
7	RAILWAY W / 20 FT. TRACK - PARTS LISTS	20
7.1	Aluminum Track Bundle 20FT	20
7.2	Cross Tie Bundle	20
7.3	Truck Bundle	20
7.4	Guide On Bundle	20
7.5	Guide Pocket Bundle	20
7.6	Bunk Bundle	20
7.7	Bunk Carton of Parts	21
7.8	Railway Carton of Parts	21

LIST OF FIGURES

FIGURE	DESCRIPTION	PAGE
2-1	Typical Product Nameplate	4
3-1	Track Assembly.....	7
3-2	Truck / Track Assembly	7
3-3	Carriage Assembly	8
3-4	Carriage Bunk Assembly.....	9
3-5	Carriage Guide On Assembly.....	10
3-6	Adjusting Bunks & Guide Ons.....	11
3-7	Guide On Cable / Track Support Assembly	12
5-1	Wire Rope Components	17

1 SAFETY

1.1 INTRODUCTION

Your Reimann & Georger Corporation Marine Products Railway Lift has been engineered to provide reliable performance, long term economics and safety advantages that no other type can match. However, even a well-designed and well-built lift can malfunction or become hazardous in the hands of an inexperienced and/or untrained user. Therefore, read this manual and related equipment manuals thoroughly before operating your lift to provide maximum safety for all operating personnel, and to get the maximum benefit from your equipment.



WARNING:

DO NOT OPERATE THIS RAILWAY LIFT WITHOUT STUDYING THIS ENTIRE MANUAL. FAILURE TO DO THIS CAN LEAD TO EQUIPMENT MISUSE WITH RESULTING DAMAGE AND/OR SERIOUS PERSONAL INJURY. CONTACT YOUR RGC® MARINE DEALER IF YOU HAVE ANY QUESTIONS.

1.2 SAFETY DEFINITIONS

A safety message alerts you to potential hazards that could hurt you or others or cause property damage. The safety messages or signal words for product safety signs are **DANGER**, **WARNING**, and **CAUTION**. Each safety message is preceded by a safety alert symbol and is defined as follows:

DANGER: Indicates an imminently hazardous situation which, if not avoided, **will** cause death or serious injury. This safety message is limited to the most extreme situations.

WARNING: Indicates a potentially hazardous situation which, if not avoided, **could** result in death or serious injury.

CAUTION: Indicates a potentially hazardous situation which, if not avoided, **may** result in minor or moderate injury. It may also be used to alert against unsafe practices and property-damage-only accidents.

1.3 EQUIPMENT SAFETY LABELS

These labels warn you of potential hazards which could cause injury. Read them carefully. If a label comes off or becomes illegible, contact a Reimann & Georger Corporation dealer for a free replacement.

1.4 EQUIPMENT AND PERSONNEL SAFETY

1. Do not use the lift if it shows any signs of damage.
2. Do not exceed the rated maximum lifting capacity of this equipment.
3. When using the power drive understand the use of all controls and connections provided with it.



WARNING:

ALL ELECTRIC DRIVES MUST BE INSTALLED AND INSPECTED BY A CERTIFIED ELECTRICIAN IN ACCORDANCE WITH LOCAL ELECTRICAL CODES. THIS INSTALLATION MUST INCLUDE A PROPERLY WORKING GROUND FAULT CIRCUIT INTERRUPTER. (G.F.C.I.)

4. Never try lifting anything other than a boat with this equipment.
5. Never allow people in the boat any time it is above the water on the carriage.



WARNING:

DO NOT STAND OR WALK ON THE PLATFORM WHILE IT IS IN ANY RAISED POSITION. THIS CAN CAUSE SERIOUS PERSONAL INJURY.

6. Do not allow anyone to swim or play under, near or on the lift at any time.

1.5 INSTALLATION SAFETY

1. Ensure that all bolts and nuts are fastened securely prior to operation.
2. Ensure the pulleys spin freely. If any pulley binds, replace it immediately.
3. Do not weld or otherwise modify the lift. Such alterations may weaken the structural integrity of the lift and void the warranty.
4. All lifting accessories such as pontoon brackets, pivoting bunks, and guide-ons, must be commercially manufactured, have a rated load capacity equal to that of the lift, and be properly maintained and installed.
5. Ensure that the frame is square.
6. The following precautions must be observed when lifting any part of this equipment:
 - a. Be sure of your footing.
 - b. Bend your knees and lift with your legs.
 - c. Hold the equipment section close to your body when lifting.
7. Wear heavy leather gloves when handling wire rope. Insufficient hand protection when handling wire rope can cause personal injury.

1.6 OPERATING SAFETY

1.6.1 General

1. Never use this equipment beyond its rated capacity. This can damage the lift and/or boat with resulting serious personal injury.
2. Before allowing anyone to operate the lift, be certain they fully understand the proper operating procedure.
3. Completely remove any user or dealer installed locking devices before operating the lift.
4. Follow the Pre-Lifting Checklist before operating.
5. Do not try lifting or launching your boat in rough water conditions. This can damage your boat and/or the lift.
6. The boat must be secured on the lift before raising or lowering. Failure to do this can cause equipment damage and/or serious personal injury.
7. Keep people and pets clear during operation of the lift.
8. Keep fingers and clothing clear of all moving parts.
9. Check the lift periodically for frayed cables and/or binding pulleys.
10. Do not attempt to make any adjustments on the lift while it is being operated.

11. Contact your dealer if the power drive fails to perform as described in the Operation chapter of the power drive manual.
12. Never tamper with the winch mechanism. This can cause equipment damage.
13. Do not operate the lift under the influence of drugs, alcohol, or medication.
14. Never use the lift to hang or store any auxiliary equipment such as boating hardware.

1.6.2 Safety When Raising the Boat

1. Be sure that the track area is clear and the boat is correctly situated on the carriage.

1.6.3 Safety When Lowering the Boat

1. Do not continue lowering the platform after the boat floats freely. Excessive slack in winch cable may cause binding.

1.7 MAINTENANCE AND STORAGE SAFETY

1. At least once a year, the lift must be thoroughly inspected as described in the Maintenance chapter of this manual.
2. Completely lower the platform before performing any type of maintenance or repair.



WARNING:

NEVER ALLOW ANYBODY TO WORK IN OR ON THE BOAT WHEN IT IS SUSPENDED ABOVE THE WATER ON THE LIFT.

3. Immediately replace any components found to be defective as described in Chapter 5—Inspection and Maintenance.

2.3 OPTIONAL EQUIPMENT

The following options are available which enable you to customize your railway for your particular operation. Installation instructions are provided as part of each option kit.

1. **#1 Track Supports** (adj. range 19-1/2" – 28-1/2" ground to top of track) - used for railway track not supported by the ground or where track must be raised for proper operation.
2. **#2 Track Supports** (adj. range 27-1/2" – 36-1/2") - see above.
3. **#3 Track Supports** (adj. range 36-1/2" – 45-1/2") - see above.
4. **Extra 10 Ft. Track Section** – for installations requiring more than the standard 20 Ft. of track. Longer wire rope will be required.
5. **Curved 10 Ft. Track Sections** – required for going over seawalls.
6. **Extra 10Ft. Steel Track Sections** – for installations having swift current or strong wave action requiring added track weight.
7. **Doorway Track Splice 2Ft.** – pivoting track section allows boathouse overhead door to fully close.
8. **Manual Switch Power Drive** – use when a remote control drive is not wanted or unable to be used due to RF interference.
9. **Remote Control Conversion 110VAC** – converts switch operated control to remote control with a range of approximately 100 Ft.
10. **Push / Pull RC Power Drive** – allows rail system to be used in very shallow incline areas to pull carriage to water.
11. **Pontoon Cradle Conversion Kit** – allows the use of RGC vertical lift pontoon cradles on railway carriage.

3 INSTALLATION AND SETUP

3.1 PRE-INSTALLATION CHECKS

1. Do not assemble the beacher railway lift if any part shows any sign of damage.
2. All boat berthing accessories such as pivoting bunks, and guide-ons, must be commercially manufactured, have a rated load capacity equal to that of the railway, and be properly maintained and installed. Consult the manufacturer's instructions provided for these accessories.
3. This product has been supplied with stainless steel hardware to protect against a harsh marine environment and provide outstanding performance. Due to the chemistry and surface condition of stainless steel, there is a natural tendency for the hardware to "gall, lock up, or seize" during assembly. To prevent this from occurring, it is **highly recommended** that the anti-seize supplied in the hardware bag be applied to the mating surfaces of all stainless steel fasteners before assembly. Lubricants containing molybdenum disulfide, graphite, mica or talc may also be used.



CAUTION:

DO NOT EXCEED THE MAXIMUM TORQUE RATING ON ALL BOLTS OF 20 FT-LBS.



WARNING:

FAILURE TO APPLY A SUITABLE LUBRICANT TO THE MATING SURFACES OF STAINLESS STEEL THREADED FASTENERS MAY CAUSE GALLING AND/OR SEIZING OF ASSEMBLY.

4. During installation, the following precautions must be observed when lifting any part of this equipment:
 - a. Be sure of your footing.
 - b. Bend your knees and lift with your legs.
 - c. Hold the equipment section close to your body when lifting.

The part reference numbers and letters used in the subassembly drawings of sections 3.2 through 3.10 are the same as those listed in the parts lists of Chapter 7.

3.2 TRACK & TRUCK ASSEMBLY

1. Refer to **Figure 3-1**. Position the track channels with the flanges facing outward.
2. Assemble two separate sections of track with three track cross ties each as shown in **Inset A**. Insert bolts from outside of track for all ties.
3. Assemble the two motor cross ties on the end of track section that the power drive will be mounted as shown.
4. Assemble the power drive track section using a track splice cross tie and two splice plates as shown in **Inset B**. (Do not join track sections together at this time.)
5. Assemble the two carriage stops on the end of track section that will be used at the water end of railway.
6. Refer to **Figure 3-2**. Install the truck assemblies onto one of the preassembled track sections described above, with captured nut housings facing away from each other as shown in **Inset D**.
7. Refer to **Figure 3-1**. Join the two preassembled track sections using the track splice cross tie and splice plate as shown in **Inset B**.
8. Tighten all track fasteners at this time.

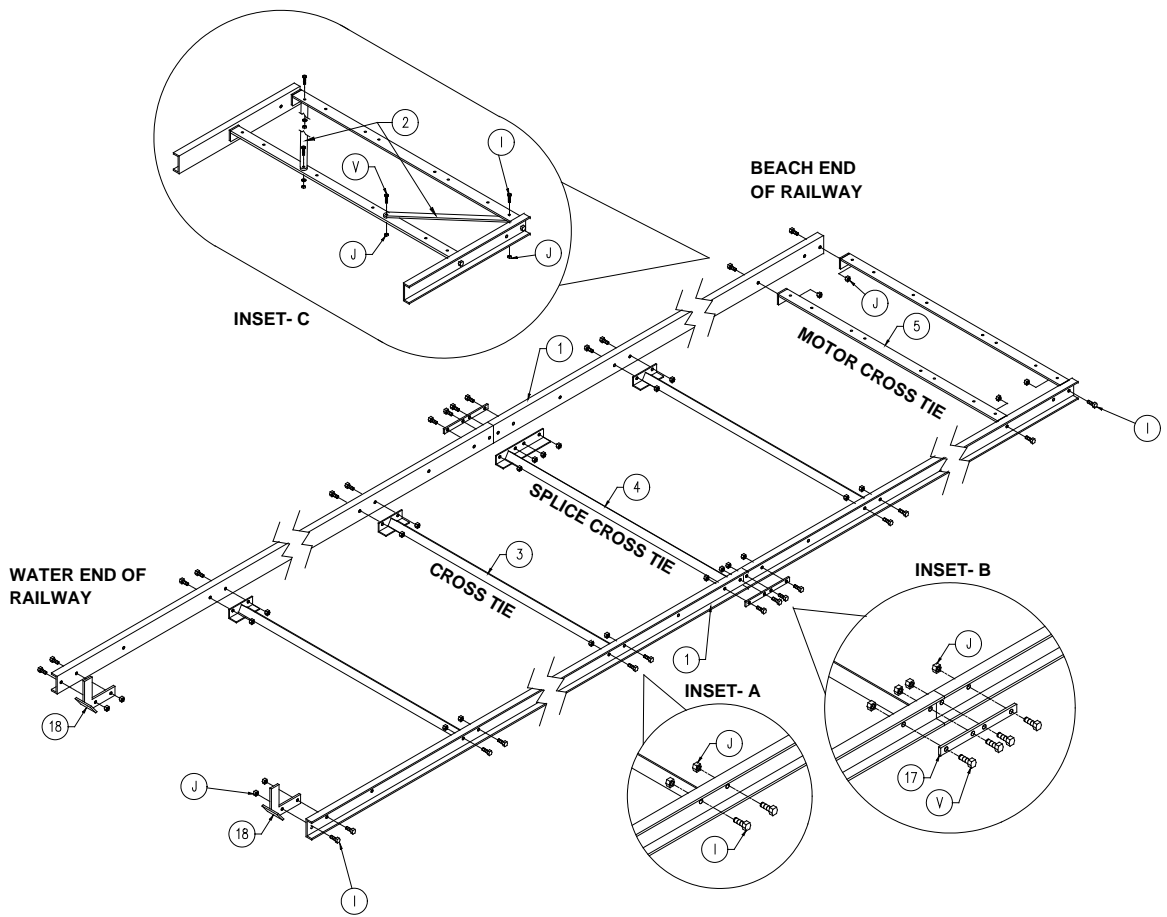

Figure 3-1.
AR6K Track Assembly

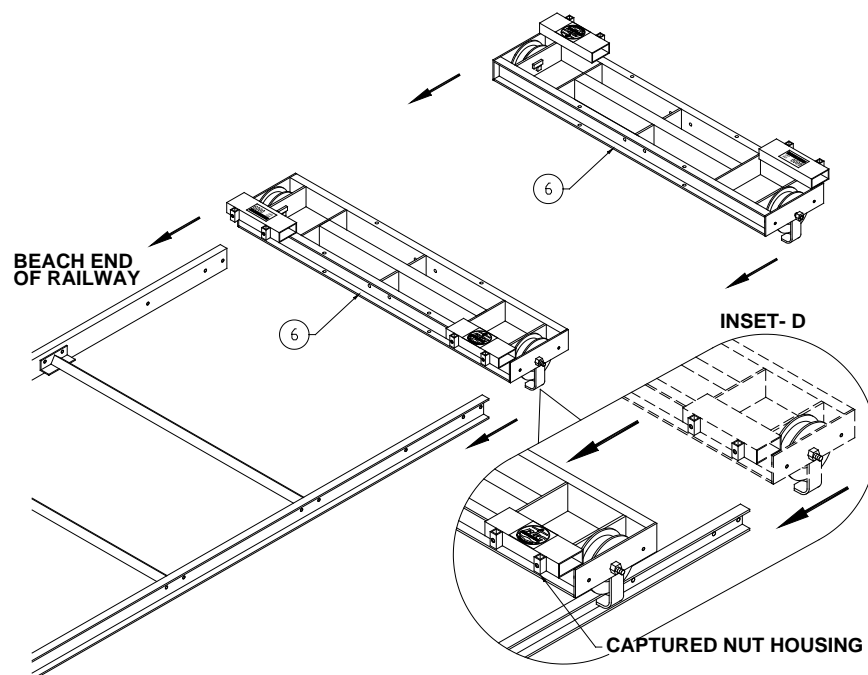

Figure 3-2.
AR6K Truck / Track Assembly

3.3 TRUCK / CARRIAGE ASSEMBLY

1. Refer to **Figure 3-3**. Starting on the same end of each truck assembly, remove the **lock nut and washer only** from the two truck wheels and attach a carriage side to each truck assembly. Reinstall wheel hardware and additional hardware as shown.
2. Repeat procedure in step 1 for other end of truck assemblies.

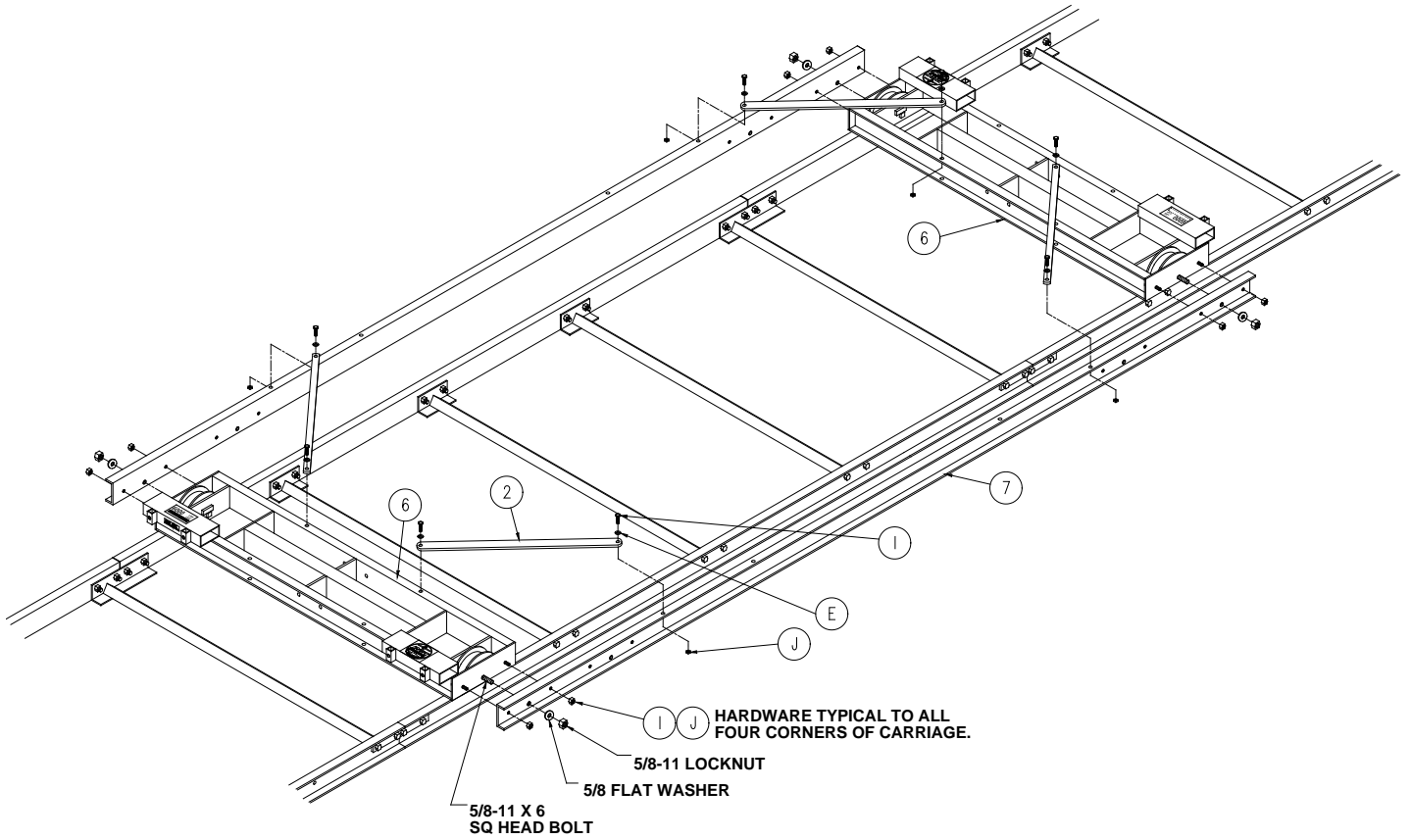

Figure 3-3.
AR6K Carriage Assembly

3.4 CARRIAGE BUNK ASSEMBLY

1. Refer to **Figure 3-4**. Locate the predrilled holes on each end of the carpeted wood bunks and puncture a hole through the carpeting with a pointed object.
2. From seamless side of carpeted wood bunk, feed two carriage bolts thru holes in carpeted wood bunk. Attach bunk cradle bracket to bunk carriage bolts and fasten as shown in **Inset E**.



CAUTION:

THE BUNK CARRIAGE BOLT HEADS MUST BE BELOW THE SURFACE OF THE CARPETED WOOD BUNKS TO PREVENT DAMAGE TO BOAT HULL.

3. Repeat procedure in step 2 for each bunk cradle bracket.
4. Assemble the angle brackets, for each bunk cradle bracket, to the truck load tubes as shown in **Inset E**. Do not tighten in place.
5. Attach each carpeted wood bunk, by the bunk cradle bracket, to the angle brackets as shown. Do not tighten.

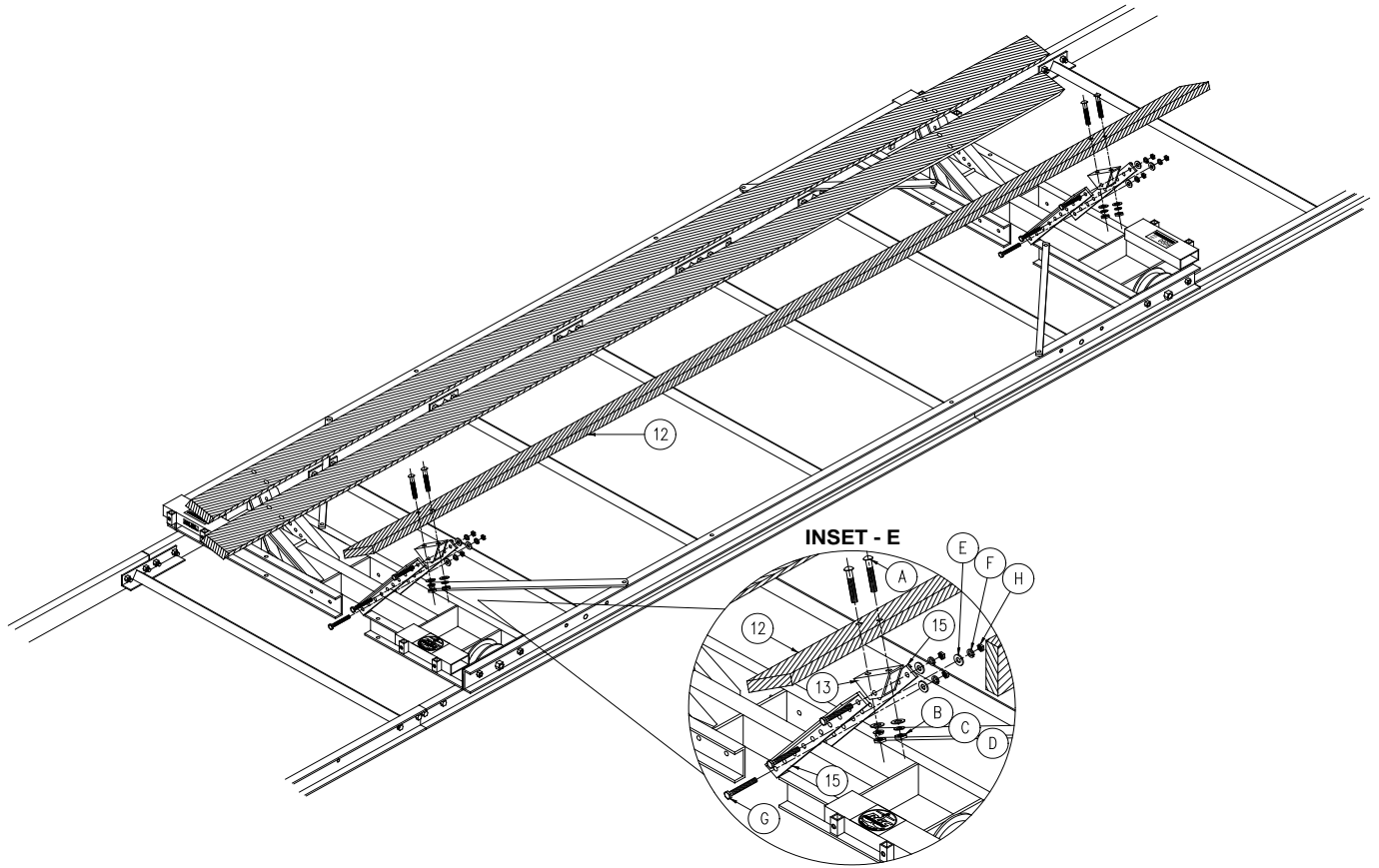

FOURTH BUNK NOT SHOWN FOR CLARITY OF ASSEMBLY

Figure 3-4.
AR6K Carriage Bunk Assembly

3.5 CARRIAGE GUIDE ON ASSEMBLY

1. Refer to **Figure 3-5**. Insert four guide post pockets into the tubes on the truck assemblies that contain the captured nut housings.
2. Assemble a bolt and nut into the captured nut housings located on the guide post pockets and truck assemblies as shown in **Inset F & G**. Do not tighten.
3. Insert the guide post into the guide post pocket assembly. Do not tighten bolts.
4. Locate the predrilled holes on each end of the carpeted wood guide ons and puncture a hole through the carpeting with a pointed object.
5. From seamless side of carpeted wood guide on, feed two carriage bolts thru holes in carpeted wood guide ons.
6. Attach the carpeted wood guide ons to the inside of guide posts with hardware shown.
7. Slide the PVC sleeves over guide posts and allow to rest on top of the carpeted wood guide ons as shown.

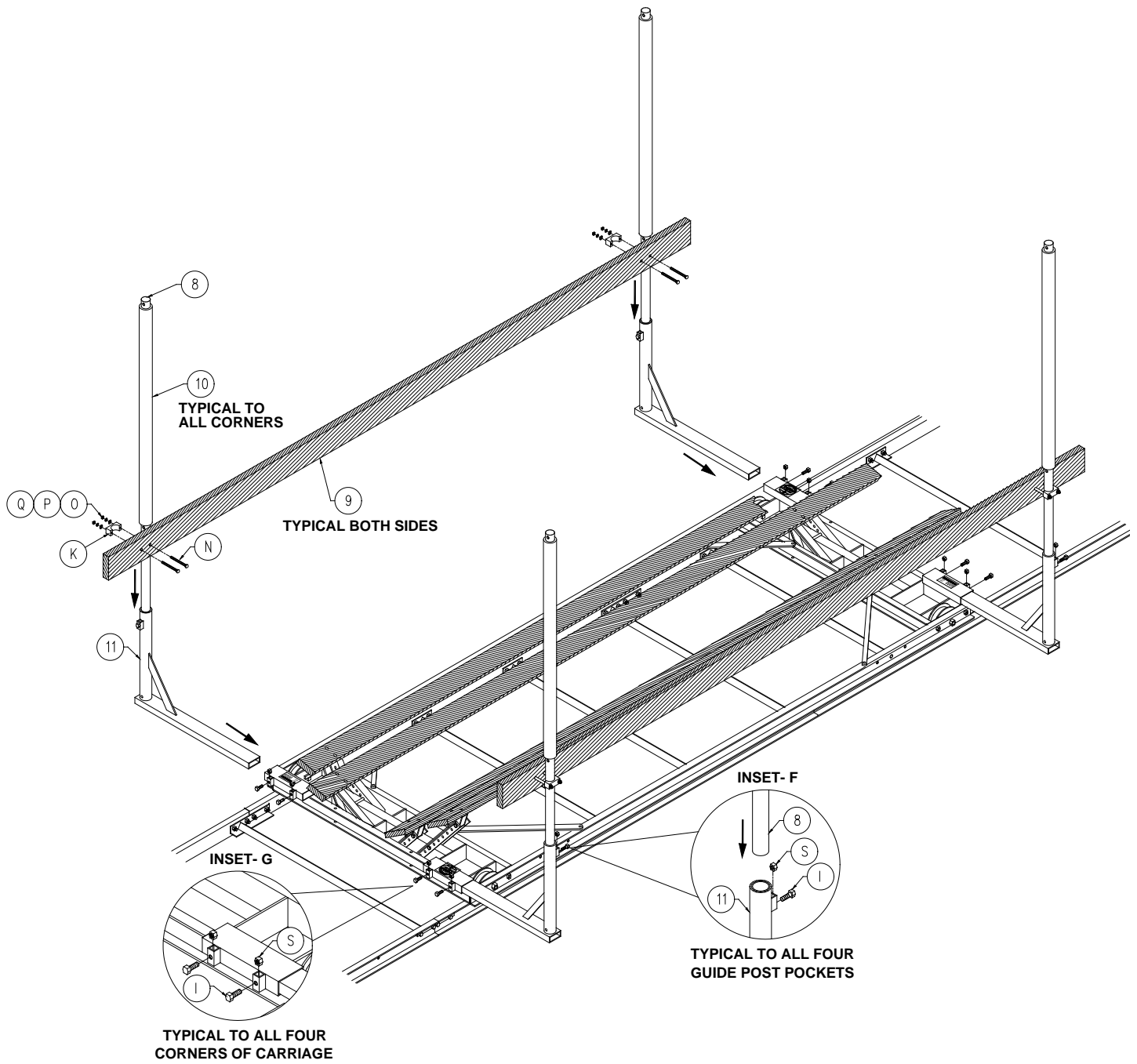

Figure 3-5.
AR6K Carriage Guide On Assembly

3.6 ADJUSTING BUNKS AND GUIDE ONS

1. Refer to **Figure 3-6**. Position the bow and stern end of carpeted wood bunks a **minimum of two feet apart** and **centered** on the load tubes. The stern end of carpeted wood bunks may be positioned slightly farther apart for improved fitting.
2. Adjust the height and angle of the carpeted wood bunks to match the profile of your boat hull. Use your boat trailer as a guide if available. Make sure brackets **do not** interfere with track cross ties below carriage.



WARNING:

ENSURE THE BUNK BRACKETS DO NOT INTERFERE WITH THE TRACK CROSS TIES TO PREVENT PERSONAL INJURY AND OR EQUIPMENT DAMAGE.



WARNING:

BUNK BRACKETS MUST BE PROPERLY POSITIONED TO PREVENT THE KEEL OF THE BOAT FROM CONTACTING THE CARRIAGE.

3. Tighten hardware for brackets to load tubes. Cradle bracket hardware should be tightened just enough to allow for pivoting adjustment of bunks when final fitting to boat hull. Tighten when final fitting is complete.
4. Adjust the distance between guide posts to suit beam of boat and wave conditions. Rough water conditions require more room between the boat and guide posts. Lock in place by tightening the bolts in the captured nut housings.
5. Position carpeted wood guide ons at a height that best suits your boat by raising the guide post. Avoid contact with boat decals if possible. Lock in place by tightening the bolts in the captured nut housings.

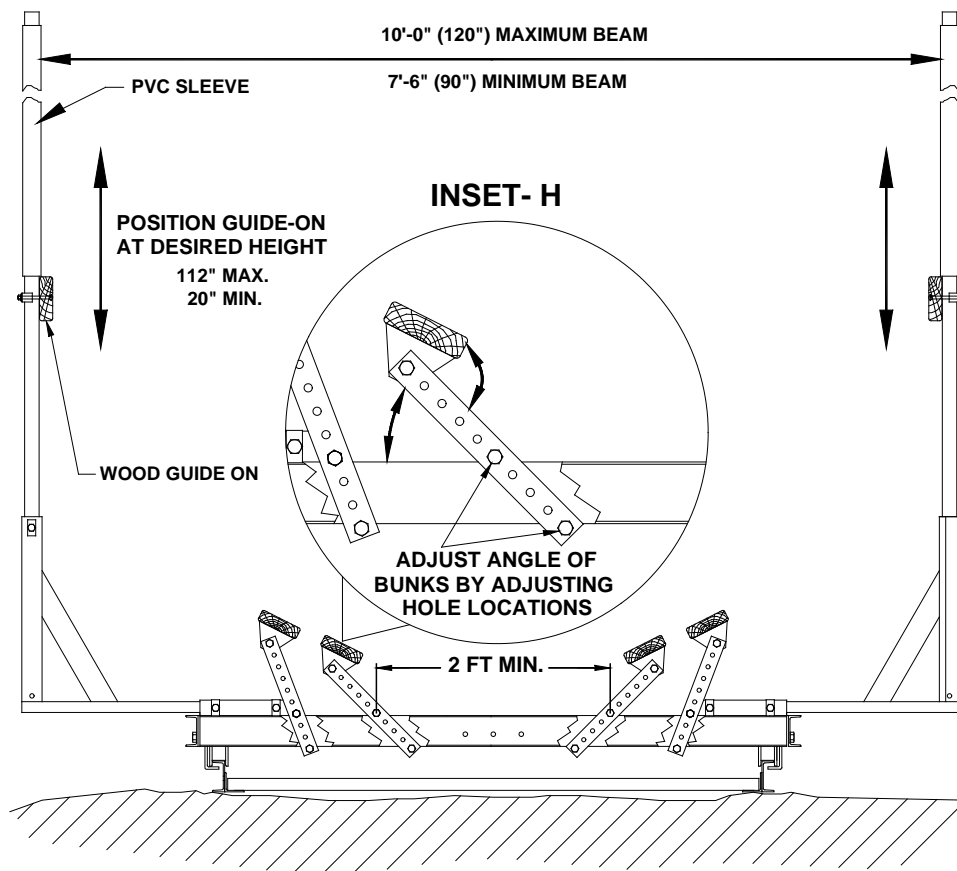

Figure 3-6.
AR6K Adjusting Bunks & Guide Ons

3.7 POSITIONING THE TRACK

1. A **minimum slope of 1 inch of height to 1 foot of track length** is recommended for carriage to roll out properly by the use of gravity. The standard power drive **DOES NOT PULL** the carriage out, it only unwinds the cable from the drum to allow rolling out of carriage. Areas with little or no grade will require use of the optional push / pull power drive to allow carriage to roll down the track and into the water.
2. Refer to **Figure 3-7**. The track must be rigidly supported at all the track splices and **every 3 1/2 feet** by the ground or by Reimann & Georger Corp. track supports as listed in **Chapter 2 - Optional Equipment** or other means for full length of track. Refer to separate installation instructions provided with these kits.



CAUTION:

THE TRACK SECTIONS MUST BE SUPPORTED AT EACH SPLICE AND EVERY 3-1/2FT FOR FULL LENGTH OF TRACK.



CAUTION:

THE TRACK SUPPORTS MUST BE VERTICALLY PLUMB TO PREVENT EQUIPMENT DAMAGE.

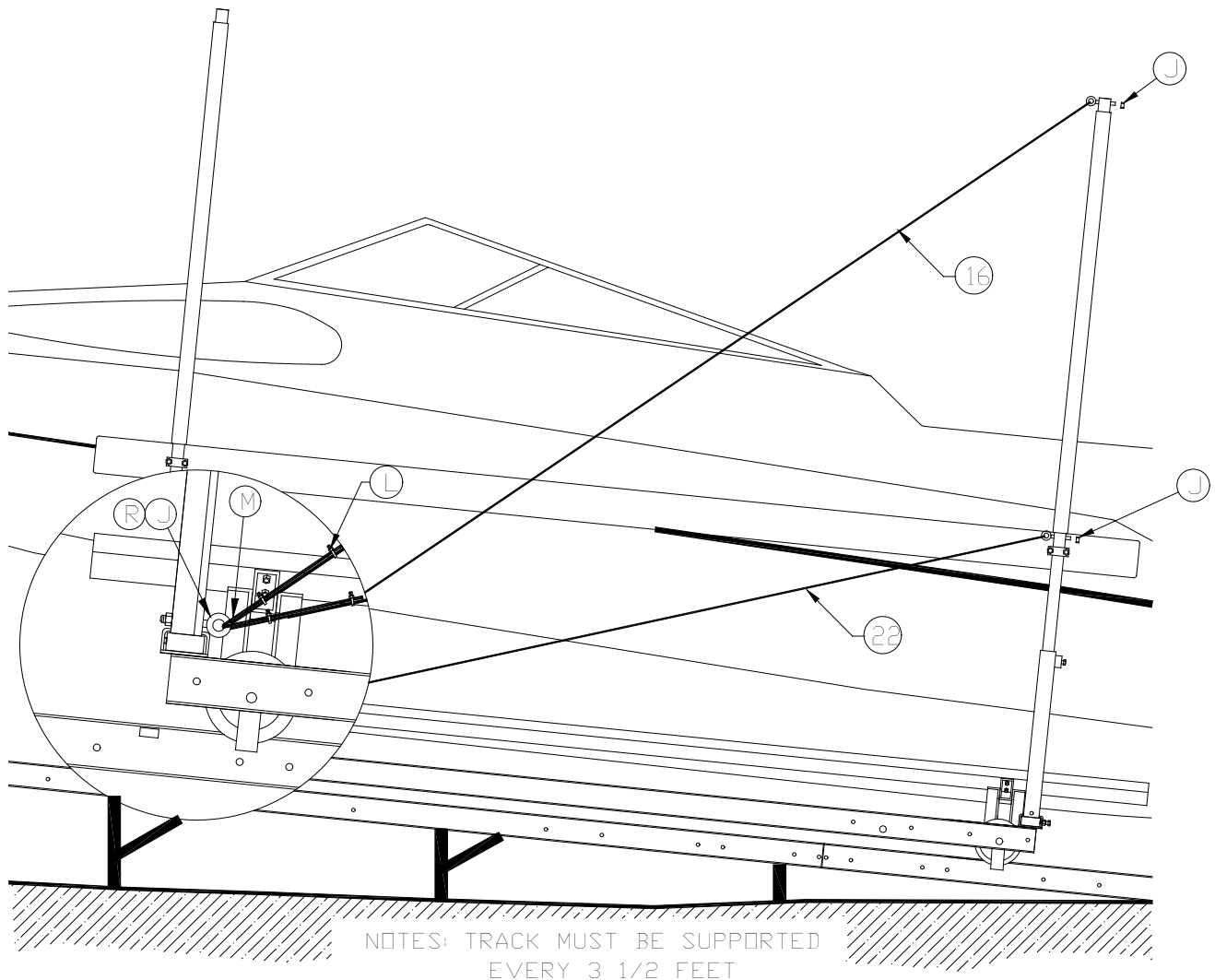

Figure 3-7.
AR6K Guide On Cable / Track Support Assembly

3.8 SECURING THE BOAT ON THE CARRIAGE

1. Refer to **Figure 3-7**. When operating the railway, tie the boat to the guide posts at the stern end of carriage. For steep uphill slopes, you must reinforce the stern and bow end guide posts using the cable assembly as shown.

3.9 FINAL ASSEMBLY CHECKLIST

The beacher and related equipment must be thoroughly inspected prior to each use. Only those who have read and understood this entire manual and related equipment manuals are qualified to do this inspection. This checklist is to be used as a guideline in conjunction with the maintenance and inspection procedures outlined in Chapter 4. It is recommended that the inspection be maintained as a permanent record.

- Ensure all structural members of the railway are free of defects and damage that may affect the integrity.
- Ensure the truck assemblies have been installed with the captured nut housings facing outward.
- Ensure the wheels on the carriage assembly spin freely. If any wheel binds, replace it immediately.
- Ensure all bolts are fastened securely prior to operation.
- Ensure the track is supported every 3 1/2 feet by either the ground or Reimann & Georger Corp. track supports
- Ensure the track supports are vertically plumb.
- Ensure the railway installation will clear all obstructions.
- Before operation, ensure the boat is properly positioned on bunks and secured on the carriage.
- Ensure the boat is tied to the guide posts at the stern of the carriage when operating the railway.
- Ensure the stern guide posts have been reinforced by the provided cable assemblies for steep uphill slopes.
- Ensure the railway is not being used beyond its rated capacity.
- Ensure that any user or dealer installed locking devices have been removed before operating the railway.
- Operate the carriage first without, and then with, your boat on the carriage to test the operation of both the carriage and the power drive.
- Conduct the wire rope inspection procedure described in Chapter 4 at least once per month.

4 OPERATION

4.1 BEFORE OPERATING THE BEACHER RAILWAY

1. Do not use the beacher if it shows any signs of damage.
2. Ensure that all bolts and nuts are fastened securely prior to operation.
3. Never try pulling anything other than the supplied carriage with this equipment.
4. Never place anything other than a boat into the carriage.
5. Completely remove any user or dealer installed locking devices.
6. Review the Final Assembly Checklist in Chapter 3 before operating.



WARNING:

NEVER TRY TO USE THIS EQUIPMENT BEYOND ITS RATED CAPACITY. THIS CAN DAMAGE THE BEACHER AND/OR BOAT RESULTING IN PERSONAL INJURY.

THE BOAT MUST BE PROPERLY POSITIONED ON THE CARRIAGE BEFORE DOING ANY BEACHING OR LAUNCHING. FAILURE TO DO THIS CAN CAUSE EQUIPMENT DAMAGE AND/OR PERSONAL INJURY.

7. Do not operate the beacher under the influence of drugs, alcohol, or medication.
8. Do not try beaching or launching your boat in rough water conditions. This can damage your boat and/or the beacher.
9. Ensure that all personnel fully understand the proper operating procedure.
10. Understand the use of all controls and connections provided with the power drive.

4.2 TESTING POWER DRIVE OPERATION

After the beacher installation is complete, it is important that the power drive functions properly. Test the power drive operation as follows:

1. Pull the empty carriage about one-fourth the way up the track and release the manual or remote control switch. If the power drive is functioning properly, the carriage will be held at any position.
2. Repeat Step 1 in the half, three-quarters, and full carriage track positions.



WARNING:

IF THE POWER DRIVE STARTS TO FREELY SPIN DOWN FROM ANY OF THESE TEST POSITIONS, NEVER TRY TO STOP IT. DO NOT USE THE BEACHER IN THIS CONDITION.

3. Lower the empty carriage to repeat steps 1 and 2 with your boat on the carriage. The power drive stops the carriage from lowering as soon as the operator releases the manual or remote control switch.
4. Contact your authorized dealer if the power drive mechanism fails to perform as described in this section. Do NOT tamper with the power drive.

4.3 RAISING AND LOWERING THE CARRIAGE



WARNING:

NEVER RIDE ON THE CARRIAGE OR INSIDE THE BOAT WHILE OPERATING THE POWER DRIVE. THE CARRIAGE IS NOT DESIGNED FOR MOVING PEOPLE, AND DOING THIS CAN CAUSE SERIOUS PERSONAL INJURY.



WARNING:

IF THE WEIGHT OF THE BOAT ON AN INCLINE EVER TRIGGERS FREEWHEELING, NEVER TRY TO STOP IT. THIS CAN CAUSE SERIOUS PERSONAL INJURY.

1. Raise and lower the carriage with the manual or remote control switch. The power drive will hold the carriage at any desired position. When lowering the carriage, do not continue after the boat floats freely from it. Excessive cable slack may cause cable, beacher, or power drive damage.
2. Keep fingers and clothing clear of all moving parts. Keep people clear during operation of the beacher.
3. Never allow people in the boat any time it is suspended above the ground on the carriage.



WARNING:

DO NOT STAND OR WALK ON THE TRACK OR CARRIAGE AFTER THE BEACHER IS INSTALLED. THIS CAN CAUSE SERIOUS PERSONAL INJURY.

4. Check the power drive and carriage periodically for frayed cables and/or binding pulleys.
5. Avoid sudden stops with the power drive.

4.4 SECURING BEACHER RAILWAY WHEN NOT IN USE

At the end of operation, secure the beacher to prevent unauthorized use. Proceed as follows:

1. Pull the carriage to the desired height.
2. Lock out your power drive to prevent unauthorized use when your boat beacher is unattended.

5 INSPECTION AND MAINTENANCE

5.1 GENERAL MAINTENANCE RULES

1. Do not allow persons other than authorized service personnel to repair this equipment.
2. Do not weld or otherwise modify the beacher. Such alterations may weaken the structural integrity of the beacher railway and invalidate your warranty.
3. Completely lower the carriage before performing any type of maintenance or repair.



WARNING:

NEVER ALLOW ANYBODY TO WORK IN OR ON THE BOAT WHEN IT IS POSITIONED ON THE CARRIAGE. IF THE POWER DRIVE SHOULD START FREEWHEELING, SERIOUS INJURY OR DEATH COULD RESULT.

IF FREEWHEELING STARTS, NEVER TRY TO STOP IT. ALTHOUGH A SPIN DOWN OR “FREEWHEELING” CAN CAUSE BEACHER OR BOAT DAMAGE, TRYING TO STOP FREEWHEELING CAN CAUSE SERIOUS PERSONAL INJURY.

5.2 WIRE ROPE INSPECTION PROCEDURE

Inspect the wire rope at least once per month for signs of wear, damage, or pinching. Inspect the entire wire rope working length. Thoroughly inspect the rope sections that pass over sheaves or drums, or that make opposing turns. Inspect wire rope and end attachments carefully. While inspecting, examine any sheaves, guards, guides, drums, flanges, and other surfaces contacting wire rope during operation. Correct any condition harming the rope in use or other damage or worn surfaces at this time.



CAUTION:

WEAR HEAVY LEATHER GLOVES WHEN HANDLING WIRE ROPE. INSUFFICIENT HAND PROTECTION WHEN HANDLING WIRE ROPE CAN CAUSE PERSONAL INJURY.

Remove and immediately replace wire rope with one or more of the following defects:

1. Corrosion
2. Broken wires:
 - (a) One or more valley breaks. A valley break is a wire break occurring in the valley between two adjacent strands.
 - (b) Six randomly distributed broken wires in one rope lay. A rope lay is the length of rope along which one strand makes a complete revolution around the rope. See **Figure 5-1**. If a broken wire or wires are localized in the end attachment of an operating rope and making a new attachment can eliminate this condition, this may be done instead of replacing the entire rope. Keeping the rope clean and wound evenly on the wire rope drum will increase its life and efficiency.
3. Abrasion: Scrubbing, flattening or peening causing loss of more than one-third of the original diameter of the outside wires.
4. Kinking: Severe kinking, crushing, bird caging or other damage causing distortion of the rope structure. Bird caging is a bulging in the wire rope caused by the individual wires becoming untwisted. This untwisting of individual wires is usually caused by impact loading on the wire rope (such as a sudden stop).

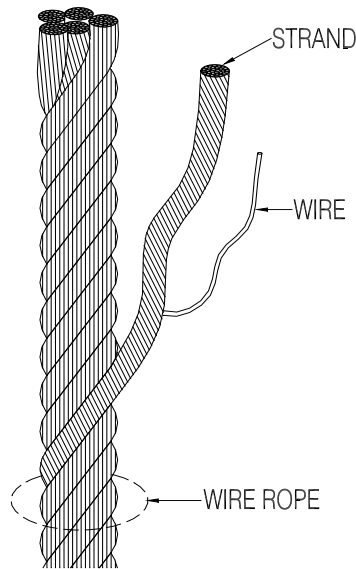

Figure 5-1.
Wire Rope Components

5. Heat damage: Evidence of any heat damage caused by a torch or by contact with electrical wires.
6. Reduction of more than 3/64 inch from 1/4 inch diameter wire rope, 1/16 inch from 5/16 inch or 3/8 inch diameter wire rope. Marked reduction in diameter indicates core deterioration.

5.3 ANNUAL INSPECTION

At least once a year, the beacher must be thoroughly inspected using the following procedure.



WARNING:

DO NOT ALLOW ANYBODY TO USE THE BEACHER RAILWAY UNTIL THIS MAINTENANCE IS COMPLETED.

1. Tighten all bolts.
2. Check the sheaves to ensure that they spin freely. If they bind, replace them immediately.
3. Check frame thoroughly for defects.
4. Perform the power drive maintenance as described in Section 5.4.

5.4 ANNUAL POWER DRIVE MAINTENANCE

1. The power drive maintenance schedule must be followed to avoid possible equipment failure or personal injury.
2. Before removing the belt guard (and drive cover if so equipped) to inspect or work on the power drive, be sure the carriage is completely lowered. Do not manipulate any of the mechanisms when the carriage is raised.
3. Lubricate cables and sheave bearings.
4. Lubricate wire rope hub.



WARNING:

AFTER EVERY POWER DRIVE MAINTENANCE, TEST THE POWER DRIVE MECHANISM AS DESCRIBED IN POWER DRIVE INSTRUCTION MANUAL BEFORE LETTING ANYONE USE THE BEACHER RAILWAY.

5.5 STORAGE PROCEDURE



CAUTION:

DO NOT STORE THE LIFT IN THE WATERWAY IF FREEZING TEMPERATURES ARE EXPECTED. THIS WILL CAUSE EQUIPMENT DAMAGE.

1. Ensure boat is properly positioned on carriage.
2. A boat that has water in it from a rainstorm could exceed the recommended weight capacity for the beacher. Just 1 gallon of water weighs over 8 pounds. Be sure to remove the plug while the boat is up on the beacher. Make sure you replace the plug prior to launching your boat.
3. Protect your beacher as far as possible from damage caused by environmental factors such as airborne fallout, chemicals, tree sap, and weather hazards.
4. Never use the beacher to hang or store any auxiliary equipment such as boating hardware.
5. Do not allow anyone to swim or play near the beacher at any time.
6. Disconnect and lock out the power to the electric motor when your beacher is unattended. Never assume you will find the beacher railway in the same condition that you left it.

6 TROUBLESHOOTING

The following chart is intended to assist with troubleshooting your beacher railway lift. While not all inclusive, the chart outlines the most common causes of a problem and the recommended course of action.

SYMPTOM	CAUSE AND CORRECTIVE ACTION
<p>Power drive fails to hold the carriage in a given position as described in the test procedure of Section 3.2</p>	<p>Contact your authorized dealer—tampering with the power drive mechanism can cause equipment damage that may invalidate your warranty.</p>
<p>Carriage raising is either difficult or impossible.</p>	<p>Carriage is binding because either frame is not square or track is not straight—refer to Chapter 3.</p> <p>Cable is rubbing against the power drive frame—repeat wire rope reeving as specified in Power Drive Manual</p> <p>One or more truck wheels is binding—inspect/lubricate/replace.</p> <p>Load exceeds rated capacity of 6000 pounds—reduce load weight as needed.</p> <p>User or dealer installed locking devices are in place—remove these.</p> <p>Auxiliary equipment such as boating hardware is being improperly hung on beacher—remove this equipment permanently.</p>
<p>Boat shifts position when operating the beacher.</p>	<p>Boat is not properly secured on the carriage—failure to properly secure boat can cause equipment damage and/or serious personal injury.</p>
<p>Launching operation triggers a “freewheeling” of the power drive.</p>	<p>Unauthorized tampering with the power drive has occurred—do not try to correct this yourself. Contact your authorized dealer immediately.</p>

7 PARTS LISTS

Each reference number or letter in the following AR6K Railway parts lists can be matched with the reference number or letter referred to in both the text and illustrations of Chapter 3, Installation and Setup.



WARNING:

FAILURE TO APPLY A SUITABLE LUBRICANT TO THE MATING SURFACES OF STAINLESS STEEL THREADED FASTENERS MAY CAUSE GALLING AND/OR SEIZING OF ASSEMBLY.

7.1 ALUMINUM TRACK BUNDLE 20FT.

REF #	PART #	QTY	DESCRIPTION
1	3562625	4	TRACK SECTION 10 FT.
2	3562753	6	MOTOR / CARRIAGE DIAGONAL BRACE

7.2 CROSS TIE BUNDLE

REF #	PART #	QTY	DESCRIPTION
3	3562480	6	TRACK CROSS TIE
4	3562475	1	TRACK SPLICE CROSS TIE
5	3562425	2	MOTOR CROSS TIE

7.3 TRUCK BUNDLE

REF #	PART #	QTY	DESCRIPTION
6	3562305	2	TRUCK ASSEMBLY

7.4 GUIDE ON BUNDLE

REF #	PART #	QTY	DESCRIPTION
7	3562620	2	CARRIAGE SIDE CHANNEL
8	3508083	4	GUIDE POST
9	3562215	2	GUIDE ON ASSEMBLY
10	3508085	4	GUIDE POST SLEEVE

7.5 GUIDE POCKET BUNDLE

REF #	PART #	QTY	DESCRIPTION
11	3508086	4	GUIDE POST POCKET ASSEMBLY

7.6 BUNK BUNDLE

REF #	PART #	QTY	DESCRIPTION
12	3562210	4	BUNK ASSEMBLY

7.7 BUNK CARTON OF PARTS

REF #	PART #	QTY	DESCRIPTION
13	3603936	8	BUNK CRADLE BRACKET 2"
15	3603938	16	CRADLE BRACKET ANGLE 15-7/8
	3562155	1	BUNK BAG OF BOLTS consisting of:
A	5896323	16	3/8 X 2-1/2 CARRIAGE BOLT
B	5896406	16	3/8 SAE FLAT WASHER
C	5806243	16	3/8 SPLIT LOCK WASHER
D	5896377	16	3/8 HEX NUT
E	5896400	24	1/2 SAE FLAT WASHER
F	5806244	24	1/2 SPLIT LOCK WASHER
G	5896290	24	1/2 X 3-1/2 HEX HEAD CAP SCREW
H	5803612	24	1/2 HEX NUT – SILICON BRONZE

7.8 RAILWAY 20FT. CARTON OF PARTS

REF #	PART #	QTY	DESCRIPTION
16	3562320	2	LONG GUIDE POST CABLE ASSEMBLY
17	3508120	2	TRACK SPLICE PLATE
18	3508093	2	CARRIAGE STOP
22	3508118	2	SHORT GUIDE POST CABLE ASSEMBLY
	3562165	1	TRACK 20 FEET BAG OF BOLTS consisting of:
I	5896282	34	1/2 X 1-1/2 HEX HEAD CAP SCREW
J	5897018	44	1/2 NYLOCK HEX NUT
V	5896283	10	1/2 X 1-3/4 HEX HEAD CAP SCREW
	3562160	1	CARRIAGE BAG OF BOLTS consisting of:
K	3403753	4	PWC COLLAR HALF
L	7306460	8	3/16 WIRE ROPE CLAMP
M	7300933	4	1/4 THIMBLE
N	5896319	8	1/4 X 4-1/2 CARRIAGE BOLT
O	5896392	8	1/4 USS FLAT WASHER
P	5896398	8	1/4 SPLIT LOCK WASHER
Q	5896373	8	1/4 HEX NUT
R	5806166	2	1/2 X 4-1/2 REGULAR EYE BOLT
S	5896385	12	1/2 SQUARE NUT
I	5896282	28	1/2 X 1-1/2 HEX HEAD CAP SCREW
J	5897018	22	1/2 NYLOCK HEX NUT
E	5896400	8	1/2 SAE FLAT WASHER

LIMITED PRODUCT WARRANTY

Reimann & Georger Corporation Marine Products

RGC Marine products, hereafter referred to as the “Manufacturer”, extends this limited warranty to the original purchaser of this product. The original purchaser, hereinafter referred to as the “Buyer”, is defined as the first legal owner of this product other than an authorized distributor or dealer who has bought the product from the Manufacturer for resale to the public. **The Buyer must complete and return the Warranty Registration section of the provided Warranty Card to make this limited warranty effective.**

CONSUMER PRODUCT PROVISIONS

I. ARTICLE I—CONSUMER PRODUCT PROVISIONS: THE FOLLOWING PROVISIONS SHALL BE APPLICABLE IF THIS PRODUCT IS BEING PURCHASED FOR PERSONAL, FAMILY OR HOUSEHOLD PURPOSES.

THE CONSUMER PRODUCT PROVISIONS CONTAINED IN THIS ARTICLE I SHALL APPLY UNLESS THIS PRODUCT IS BEING PURCHASED SOLELY FOR COMMERCIAL OR INDUSTRIAL USE, IN WHICH EVENT THE PROVISIONS CONTAINED IN ARTICLE II BELOW SHALL APPLY AND THE PROVISIONS CONTAINED IN THIS ARTICLE I SHALL BE INAPPLICABLE.

A. 2-YEAR LIMITED WARRANTY

The Manufacturer warrants to the Buyer that all supplied parts shall be free of defects in material and workmanship for a period of two (2) years from date of original purchase. This limited warranty covers the cost of all parts and labor needed to repair any item that is found to be defective in material and workmanship. Items covered include cables, sheaves, chains, motors, reducers, switches, control panels and ground fault circuit interrupters.

B. 15-YEAR LIMITED WARRANTY ON ALUMINUM FRAME EXTRUSION

The Manufacturer warrants to the Buyer that the frame and extrusions shall be free of defects in material and workmanship for a period of fifteen (15) years from date of original purchase. This limited warranty covers the cost of all parts and labor needed to repair any item that is found to be defective in material and workmanship.

C. MANUFACTURER’S OBLIGATIONS

The Manufacturer’s sole obligation under either of these limited warranties is the replacement or repair, at the Manufacturer’s discretion, of parts found to be defective.

D. NO SPECIAL, INCIDENTAL OR CONSEQUENTIAL DAMAGES

IN NO EVENT SHALL THE MANUFACTURER BE LIABLE TO THE BUYER OR ANY PERSON FOR ANY INDIRECT, SPECIAL, INCIDENTAL, OR CONSEQUENTIAL LOSSES OR DAMAGES CONNECTED WITH THE USE OF THE PRODUCT UNDER WARRANTY. SUCH DAMAGES FOR WHICH THE MANUFACTURER SHALL NOT BE RESPONSIBLE INCLUDE, BUT ARE NOT LIMITED TO, LOST TIME AND CONVENIENCE, LOSS OF USE OF THE PRODUCT, THE COST OF A PRODUCT RENTAL, COSTS OF GASOLINE, TELEPHONE, TRAVEL, OR LODGING, THE LOSS OF PERSONAL OR COMMERCIAL PROPERTY, AND THE LOSS OF REVENUE.

Some States do not allow the exclusion or limitation of incidental or consequential damages, so the above limitation or exclusion may not apply to you.

E. NO LIABILITY IN EXCESS OF PURCHASE PRICE

IN NO EVENT SHALL THE MANUFACTURER’S OBLIGATIONS UNDER THIS LIMITED WARRANTY EXCEED THE PURCHASE PRICE OF THE PRODUCT.

F. NO EXTENSION OF STATUTE OF LIMITATIONS

ANY REPAIRS PERFORMED UNDER EITHER OF THESE WARRANTIES SHALL NOT IN ANY WAY EXTEND THE TWO-YEAR AND FIFTEEN-YEAR STATUTES OF LIMITATIONS CONTAINED IN THIS LIMITED WARRANTY.

G. PROCEDURE FOR WARRANTY PERFORMANCE

If the product fails to perform to the Manufacturer's specifications, the Buyer must contact the dealer from whom the product was purchased. The Buyer must provide the dealer with the applicable model and serial numbers, the date of purchase, and the nature of the problem.

H. PREAPPROVAL OF LABOR COSTS

All labor costs related to a dealer's performance of the warranty obligations under this limited warranty must be pre-approved by Reimann & Georger Corp. Marine Products.

I. NO OTHER EXPRESS WARRANTIES

THE MANUFACTURER IS NOT SUBJECT TO ANY EXPRESS WARRANTIES OTHER THAN THOSE SET FORTH ABOVE.

J. LIMIT ON DURATION OF IMPLIED WARRANTIES

THE DURATION OF ANY IMPLIED WARRANTIES UNDER APPLICABLE STATE LAW RELATING TO THE PURCHASE OF THIS PRODUCT SHALL BE LIMITED TO A PERIOD OF TWO (2) YEARS FROM THE DATE OF PURCHASE.

Some States do not allow limitations on how long an implied warranty lasts, so the above limitations may not apply to you.

K. QUESTIONS REGARDING LIMITED WARRANTY

Any questions regarding this limited warranty or the procedure which the consumer should follow in order to obtain performance of any warranty obligation may be addressed to either the dealer from whom this product is purchased or to Reimann & Georger Corp. Marine Products, P.O. Box 681, Buffalo, NY 14240.

L. EXCLUSIONS FROM LIMITED WARRANTY. THIS LIMITED WARRANTY DOES NOT COVER ANY OF THE FOLLOWING:

1. Equipment which has been abused, damaged, used beyond rated capacity, or which is damaged or has defects caused by repairs or service completed by persons other than authorized service personnel.
2. Costs of repairing damage caused by environmental factors which include, but are not limited to, airborne fallout, chemicals, tree sap, salt, ocean spray, and water hazards.
3. Damage caused by acts of God which include, but are not limited to, hailstorms, windstorms, tornadoes, sandstorms, lightning, floods, and earthquakes.
4. Damage under conditions caused by fire or accident, by abuse or negligence, by improper installation, by misuse, by incorrect operation, by "normal wear and tear", by improper adjustment or alteration, by alterations not done by the Manufacturer, or by failure of product parts from such alterations.
5. Costs of repairing damage caused by poor or improper maintenance, costs of normally scheduled maintenance, or the cost of replacing any parts unless done as the result of a repair covered by your two-year limited warranty.
6. Costs of modifying the product in any way once delivered to the Buyer, even if such modifications were added as a production change on other products made after the Buyer's product was built.

M. RIGHT TO MODIFY PRODUCT

The Manufacturer has the right to modify this product at any time without incurring any obligation to make the same or similar modifications on products previously purchased.

N. NO AUTHORITY TO ALTER WARRANTY

No agent, representative, distributor or dealer has any authority to alter the terms of this warranty in any way.

O. SPECIFIC LEGAL RIGHTS

This warranty gives you specific legal rights and you may also have other rights which vary from State to State.

COMMERCIAL PRODUCT PROVISIONS

II. ARTICLE II—COMMERCIAL PRODUCT PROVISIONS: THE FOLLOWING PROVISIONS SHALL BE APPLICABLE ONLY IF THIS PRODUCT IS BEING PURCHASED SOLELY FOR COMMERCIAL OR INDUSTRIAL USE. IF THIS PRODUCT IS BEING PURCHASED FOR PERSONAL, FAMILY OR HOUSEHOLD PURPOSES, THE PROVISIONS CONTAINED IN THIS ARTICLE II SHALL NOT BE APPLICABLE AND THE PROVISIONS CONTAINED IN ARTICLE I ABOVE SHALL APPLY.

A. 1-YEAR LIMITED WARRANTY

The Manufacturer warrants to the Buyer that all supplied parts shall be free of defects in material and workmanship for a period of one (1) year from date of original purchase. This limited warranty covers the cost of all parts and labor needed to repair any item that is found to be defective in material and workmanship. Items covered include cables, sheaves, chains, motors, reducers, switches, control panels and ground fault circuit interrupters.

B. 5-YEAR LIMITED WARRANTY ON ALUMINUM FRAME EXTRUSION

The Manufacturer warrants to the Buyer that the frame and extrusions shall be free of defects in material and workmanship for a period of five (5) years from date of original purchase. This limited warranty covers the cost of all parts and labor needed to repair any item that is found to be defective in material and workmanship.

C. MANUFACTURER'S OBLIGATIONS

The Manufacturer's sole obligation under either of these limited warranties is the replacement or repair, at the Manufacturer's discretion, of parts found to be defective.

D. NO SPECIAL, INCIDENTAL, OR CONSEQUENTIAL DAMAGES

IN NO EVENT SHALL THE MANUFACTURER BE LIABLE TO THE BUYER OR ANY PERSON FOR ANY INDIRECT, SPECIAL, INCIDENTAL, OR CONSEQUENTIAL LOSSES OR DAMAGES CONNECTED WITH THE USE OF THE PRODUCT UNDER WARRANTY. SUCH DAMAGES FOR WHICH THE MANUFACTURER SHALL NOT BE RESPONSIBLE INCLUDE, BUT ARE NOT LIMITED TO, LOST TIME AND CONVENIENCE, LOSS OF USE OF THE PRODUCT, THE COST OF A PRODUCT RENTAL, COSTS OF GASOLINE, TELEPHONE, TRAVEL, OR LODGING, THE LOSS OF PERSONAL OR COMMERCIAL PROPERTY, AND THE LOSS OF REVENUE.

E. NO LIABILITY IN EXCESS OF PURCHASE PRICE

IN NO EVENT SHALL THE MANUFACTURER'S OBLIGATIONS UNDER THIS LIMITED WARRANTY EXCEED THE PURCHASE PRICE OF THE PRODUCT.

F. NO EXTENSION OF STATUTE OF LIMITATIONS

ANY REPAIRS PERFORMED UNDER EITHER OF THESE WARRANTIES SHALL NOT IN ANY WAY EXTEND THE RESPECTIVE STATUTES OF LIMITATIONS CONTAINED IN THIS LIMITED WARRANTY.

G. WAIVER OF OTHER WARRANTIES

THESE EXPRESS WARRANTIES ARE IN LIEU OF AND EXCLUDE ANY AND ALL OTHER WARRANTIES, EXPRESS OR IMPLIED, INCLUDING, BUT NOT LIMITED TO, THE IMPLIED WARRANTIES OR MERCHANTABILITY AND FITNESS FOR A PARTICULAR PURPOSE.

H. PROCEDURE FOR WARRANTY PERFORMANCE

If the product fails to perform to the Manufacturer's specifications, the Buyer must contact the dealer from whom the product was purchased. The Buyer must provide the dealer with the applicable model and serial numbers, the date of purchase, and the nature of the problem.

I. PREAPPROVAL OF LABOR COSTS

All labor costs related to a dealer's performance of the warranty obligations under this limited warranty must be pre-approved by Reimann & Georger Corp. Marine Products.

J. EXCLUSIONS FROM WARRANTY. THIS LIMITED WARRANTY DOES NOT COVER ANY OF THE FOLLOWING:

1. Equipment which has been abused, damaged, used beyond rated capacity, or which is damaged or has defects caused by repairs or service completed by persons other than authorized service personnel.
2. Costs of repairing damage caused by environmental factors which include, but are not limited to, airborne fallout, chemicals, tree sap, salt, ocean spray, and water hazards.
3. Damage caused by acts of God which include, but are not limited to, hailstorms, windstorms, tornadoes, sandstorms, lightning, floods, and earthquakes.
4. Damage under conditions caused by fire or accident, by abuse or negligence, by improper installation, by misuse, by incorrect operation, by "normal wear and tear", by improper adjustment or alteration, by alterations not done by the Manufacturer, or by failure of product parts from such alterations.
5. Costs of repairing damage caused by poor or improper maintenance, costs of normally scheduled maintenance, or the cost of replacing any parts unless done as the result of a repair covered by your one-year limited warranty.
6. Costs of modifying the product in any way once delivered to the Buyer, even if such modifications were added as a production change on other products made after the Buyer's product was built.

K. RIGHT TO MODIFY PRODUCT

The Manufacturer has the right to modify this product at any time without incurring any obligation to make the same or similar modifications on products previously purchased.

L. NO AUTHORITY TO ALTER WARRANTY

No agent, representative, distributor, or dealer has any authority to alter the terms of this warranty in any way.

M. SPECIFIC LEGAL RIGHTS

This warranty gives you specific legal rights, and you may also have other rights which vary from State to State.