



FRICITION DRIVE-R18

110V/12V (2014)

INSTRUCTIONS

(Applies to P/Ns 6537550 & 6537553)

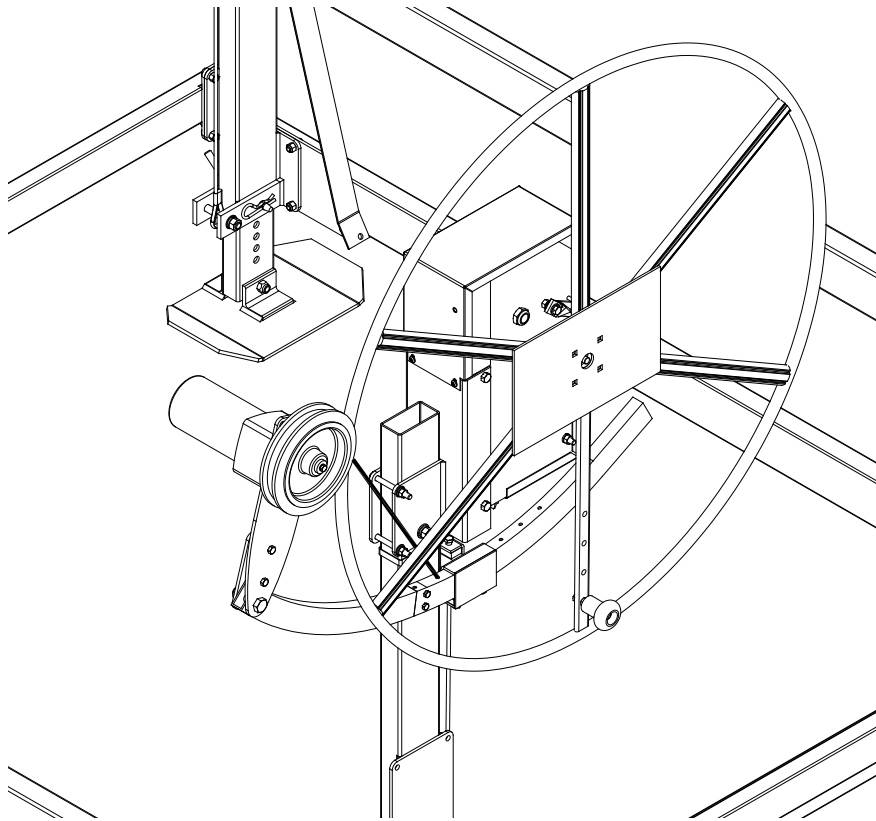

TABLE OF CONTENTS

CHAPTER	TITLE	PAGE
1	SAFETY	1
1.1	Introduction	1
1.2	Safety Definitions	1
1.3	Equipment Safety Labels	1
1.4	Safety Rules	1
2	INSTALLATION AND SETUP	3
2.1	Pre-Installation Checks	3
2.2	Prior To Setup	3
2.3	Friction Drive Mounting Arm Assembly	3
2.4	Friction Drive Assembly	5
3	SPECIFICATIONS AND OPERATION	6
3.1	Specifications.....	6
3.2	Operation	6
4	PARTS LISTS	7
4.1	Friction Drive 12Volt DC.....	7
4.2	Friction Drive 110Volt AC.....	7

LIST OF FIGURES

FIGURE	DESCRIPTION	PAGE
2-1	Mounting Arm Assembly- Front View	4
2-2	Mounting Arm Assembly- Rear View	4

1 SAFETY

1.1 INTRODUCTION

Your Reimann & Georger Corporation Marine Products Friction Drive-R18 is designed to aid in the raising and lowering of boats on the lift. Your Hand Winch Friction Drive is well-designed and well-built. However, like any other equipment, it can malfunction or become hazardous in the hands of an inexperienced and/or untrained user. Therefore, read this manual and your related Lift manual, and optional equipment manuals thoroughly before installing this kit and operating your lift to provide maximum safety for all operating personnel, and to get the maximum benefit from your equipment.

1.2 SAFETY DEFINITIONS

A safety message alerts you to potential hazards that could hurt you or others or cause property damage. The safety messages or signal words for product safety signs are **DANGER**, **WARNING**, and **CAUTION**. Each safety message is preceded by a safety alert symbol and is defined as follows:

DANGER: Indicates an imminently hazardous situation which, if not avoided, **will** cause death or serious injury. This safety message is limited to the most extreme situations.

WARNING: Indicates a potentially hazardous situation which, if not avoided, **could** result in death or serious injury.

CAUTION: Indicates a potentially hazardous situation which, if not avoided, **may** result in minor or moderate injury. It may also be used to alert against unsafe practices and property-damage-only accidents.

1.3 EQUIPMENT SAFETY LABELS

These labels warn you of potential hazards that could cause injury. Read them carefully. If a label comes off or becomes illegible, contact a Reimann & Georger Corporation dealer for a replacement.

1.4 SAFETY RULES



WARNING:

DO NOT INSTALL THIS KIT AND OPERATE THE LIFT WITHOUT READING BOTH THIS MANUAL AND YOUR VERTICAL LIFT MANUAL. FAILURE TO DO THIS CAN LEAD TO EQUIPMENT MISUSE WITH RESULTING DAMAGE AND/OR SERIOUS PERSONAL INJURY. CONTACT YOUR RGC® MARINE DEALER IF YOU HAVE ANY QUESTIONS.

1. Do not install this kit without first replacing any damaged or defective parts.
2. The Friction Drive does not increase the rated capacity of the lift. Never use the lift beyond its rated capacity. This can damage the kit assembly, lift, and/or boat with resulting serious personal injury.
3. Never try using any part of this kit in an application for which it was not designed.
4. Do not weld or otherwise modify any part of this kit. Such alterations may weaken the structural integrity of the lift and void the warranty.
5. Do not try installing the Friction Drive with the weight of the boat on the lift. This can cause equipment damage and/or personal injury.
6. The following precautions must be observed when lifting any part of this equipment:
 - a. Be sure of your footing.
 - b. Bend your knees and lift with your legs.
 - c. Hold the equipment section close to your body when lifting.
7. After the Friction Drive is installed, the safety checks in Steps 8 through 25 must be performed on your lift prior to operation. Details on these checks are given in your lift manual.
8. Before allowing anyone to operate the lift, be sure they fully understand the proper operating procedure.

9. Do not operate the lift under the influence of drugs, alcohol, or medication.
10. Keep people and pets clear during operation of the lift.
11. Keep fingers and clothing clear of all moving parts.
12. Never allow people in the boat any time it is suspended above the water on the platform.



WARNING:

DO NOT STAND OR WALK ON THE PLATFORM WHILE IT IS IN ANY RAISED POSITION. THIS CAN CAUSE SERIOUS PERSONAL INJURY.

13. Do not allow anyone to swim or play under, near or on the lift at any time.
14. Insure that all bolts and nuts are fastened securely on both this kit and the lift prior to operation.
15. Insure that the frame is level and square.
16. Completely remove any user or dealer installed locking devices before operating the lift.
17. The boat must be secured on the lift before raising or lowering. Failure to do this can cause equipment damage and/or serious personal injury.
18. Check the lift periodically for frayed cables and/or binding pulleys. If any pulley binds, replace it immediately.
19. Do not try making any adjustments on the lift during operation.
20. Contact your dealer if the winch mechanism fails to perform as described in the Operation chapter of your lift manual.
21. Never tamper with the winch mechanism. This can cause equipment damage.
22. When using a motorized friction drive, understand the use of all controls and connections provided with it.



WARNING:

ALL ELECTRIC DRIVES MUST BE INSTALLED AND INSPECTED BY A CERTIFIED ELECTRICIAN IN ACCORDANCE WITH LOCAL ELECTRICAL CODES. THIS INSTALLATION MUST INCLUDE A PROPERLY WORKING GROUND FAULT CIRCUIT INTERRUPTER. (G.F.C.I.)

23. Never use the lift to hang or store any auxiliary equipment such as boating hardware.
24. The handwheel must turn clockwise when raising the platform and counter-clockwise when lowering the platform. If the platform operates in the reverse sense, you have reeved the winch incorrectly. You **MUST** follow the winch reeving instructions in your lift manual to prevent equipment damage and/or personal injury. The brake pawl must click during platform raising, indicating that the brake is operative. The self-activating brake mechanism must provide a controlled lowering of the platform.



WARNING:

NEVER RELEASE THE BRAKE PAWL OF THE WINCH. THIS CAN TRIGGER AN UNCONTROLLED SPIN-DOWN OR “FREEWHEEL” OF THE HANDWHEEL. IF FREEWHEELING OCCURS, NEVER TRY TO STOP IT AS THIS CAN CAUSE SERIOUS PERSONAL INJURY.

25. Padlock the Handwheel to the post and lock out your friction drive to prevent unauthorized use when your lift is left unattended.

2 INSTALLATION AND SET UP

2.1 PRE-INSTALLATION CHECKS

1. Do not assemble this kit or any other component of the lift if any part appears to be damaged.
2. Do not weld or other wise modify any portion of the lift. Such alterations may weaken the structural integrity of the lift and void the warranty.

2.2 PRIOR TO SETUP

The aluminum bracket system is designed to fit all standard boatlifts. One fits all! It can be mounted on the left or right, above or below the winch, short or long, and used either straight or bent by just aligning the holes in the inner arm with the holes in the outer arm.

- Always mount the unit towards the left side of the handwheel of boatlift.
- Do not mount the unit towards the ends of the boatlift.
- Flip the motor up and over pivot so that it rests on the lift's handwheel.
- Do not hang the motor down from the arm.
- Always mount motor toward boat, not over dock.



WARNING:

ALL ELECTRIC DRIVES MUST BE INSTALLED AND INSPECTED BY A CERTIFIED ELECTRICIAN IN ACCORDANCE WITH LOCAL ELECTRICAL CODES. THIS INSTALLATION MUST INCLUDE A PROPERLY WORKING GROUND FAULT CIRCUIT INTERRUPTER. (G.F.C.I.)

2.3 FRICTION DRIVE MOUNTING ARM ASSEMBLY

Determine by your boatlift winch location, if you need to mount the friction drive on the left (10:00 o'clock position) or right side (2:00 O'clock position) of the winch post. The friction drive motor must always be mounted above the outer mounting arm, not hanging below the arm.

Refer to the Extreme Max Products Installation & Use Instruction Sheet that comes with the friction drive.

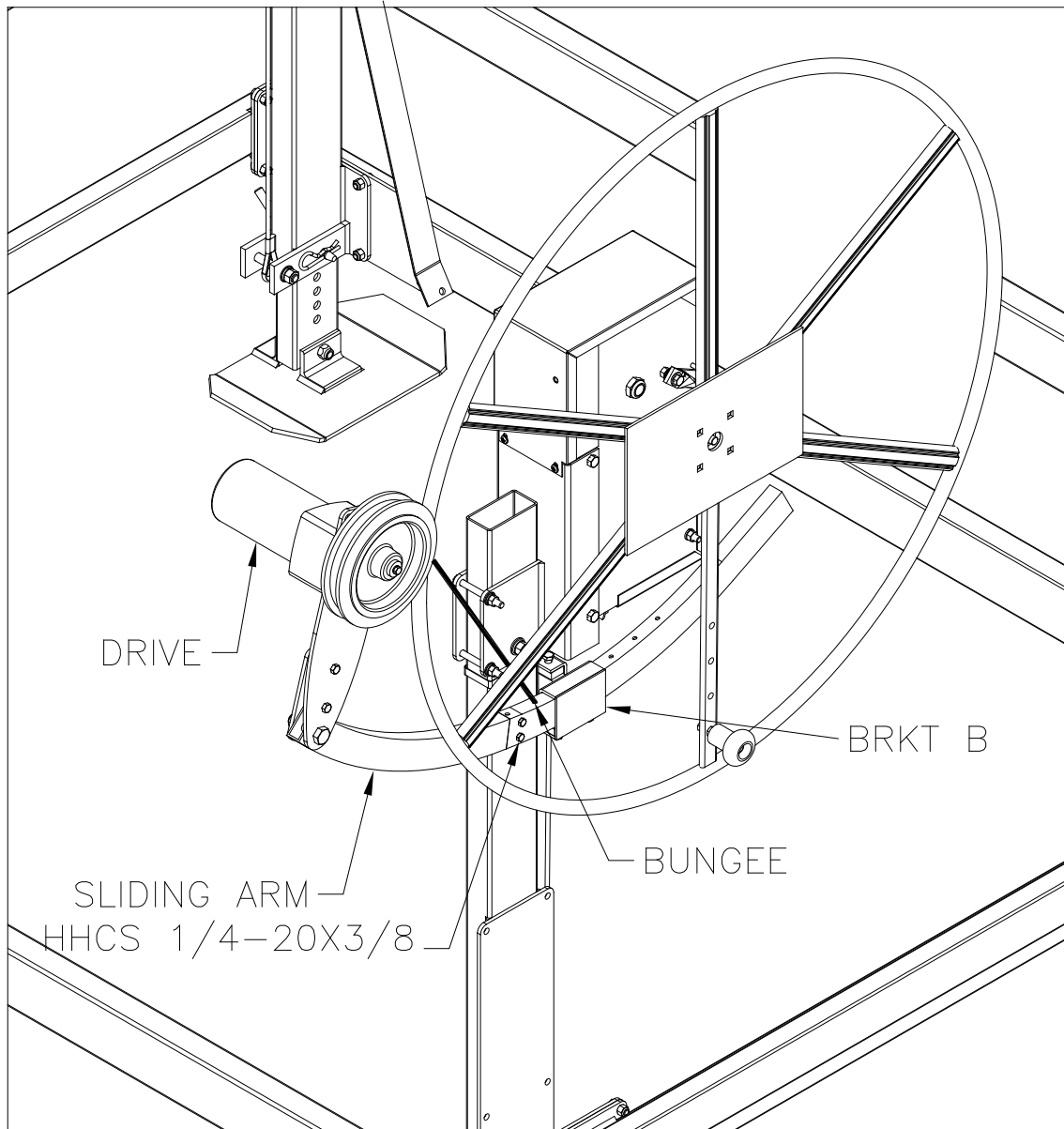

(Figure 2-1.)
Friction Drive Motor Final Assembly- Front View

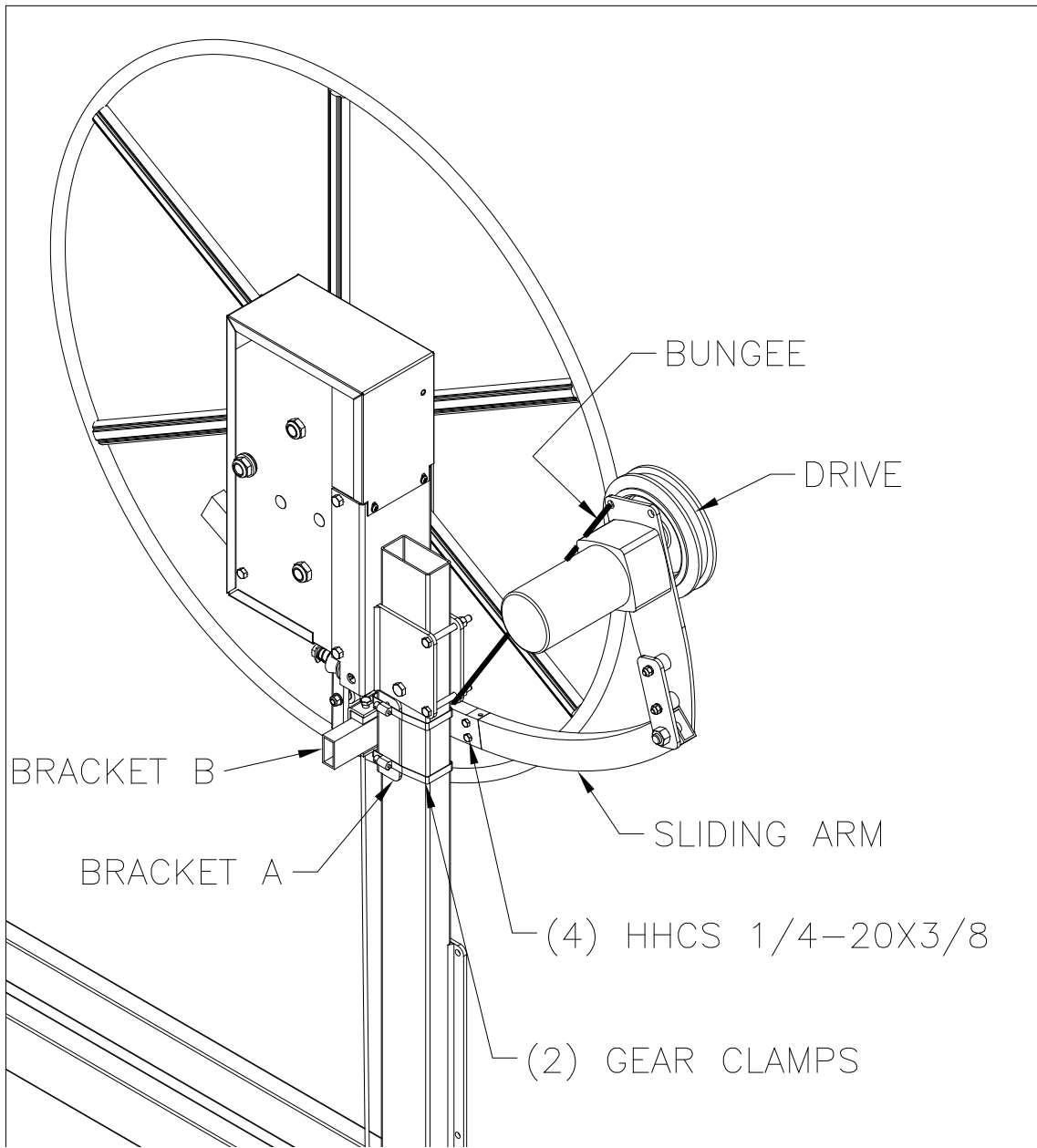

(Figure 2-2.)
Friction Drive Motor Final Assembly- rear View

3 SPECIFICATION AND OPERATION

3.1 SPECIFICATIONS

1. The motor should be connected to the proper power source, either 110V AC or 12V DC. (See motor decal.) The motor should be connected to a properly rated branch circuit to minimize voltage drops during normal operation.
2. 115 volt AC: 5.0 full load Amps: 1/3 HP: 190 RPM @ Full load.
3. 12 volt DC: 40.0 full load Amps: 1/3 HP.



WARNING:

ALL ELECTRIC DRIVES MUST BE INSTALLED AND INSPECTED BY A CERTIFIED ELECTRICIAN IN ACCORDANCE WITH LOCAL ELECTRICAL CODES. THIS INSTALLATION MUST INCLUDE A PROPERLY WORKING GROUND FAULT CIRCUIT INTERRUPTER. (G.F.C.I.)

3.2 OPERATION

Do not use the friction drive if the power cord insulation is damaged. **Replace or repair immediately.** Never reach through the Handwheel spokes. Serious personal injury may result.

1. **To raise the lift:** Push and hold up the toggle switch. (Handwheel must turn clockwise to raise) until hoist platform and boat are at desired level.
2. Release the switch at any time to stop the lift and Handwheel.

WARNING: DO NOT continue to raise the boat once the platform is within 1” of winch bottom. Hoist and power drive damage may result

3. **To lower the lift:** Push and hold down the toggle switch. (Handwheel must turn Counterclockwise to lower.)
4. Release the switch at any time to stop the lift and Handwheel.

WARNING: DO NOT continue to lower the platform once the boat floats freely, or the winch cable goes slack. Cable and winch damage may result



WARNING:

WATER AND ELECTRICITY POSE A POTENTIALLY DANGEROUS SITUATION! THE FACTORY INSTALLED IN-LINE GFCI ONLY PROTECTS THE LINE TO THE MOTOR. (110V AC MODELS ONLY) YOU MUST ALSO PROTECT THE INCOMING POWER LINE WITH AN APPROPRIATE G.F.C.I. CIRCUIT BREAKER AT THE ELECTRIC SERVICE

4 PARTS LIST

Each reference number on this parts list can be matched with the reference numbers shown on figures 2-1 through 2-3 in Section 2.3 & 2.4 of this manual.

4.1 6537550 FRICTION DRIVE 12 VOLT DC

REF #	PART #	QTY	DESCRIPTION
1		1	BRACKET A
2		1	BRACKET B
3		1	SLIDING LOWER ARM
4		1	SLIDING UPPER ARM
5		2	CLAMP BLOCK (TAPPED)
6		4	HHCS 3/8-16 X 1-1/4 CZP
7		1	HHCS 5/8-11 X 2-1/2
8		2	NUT HEX 5/8-11 SS
9		1	FRIC DR 12VDC
10		1	TENSION CORD
11		2	GEAR CLAMPS

4.2 6537553 FRICTION DRIVE 115 VOLT AC

REF #	PART #	QTY	DESCRIPTION
1		1	BRACKET A
2		1	BRACKET B
3		1	SLIDING LOWER ARM
4		1	SLIDING UPPER ARM
5		2	CLAMP BLOCK (TAPPED)
6		4	HHCS 3/8-16 X 1-1/4 CZP
7		1	HHCS 5/8-11 X 2-1/2
8		2	NUT HEX 5/8-11 SS
9		1	FRIC DR 115VAC
10		1	TENSION CORD
11		2	GEAR CLAMPS