

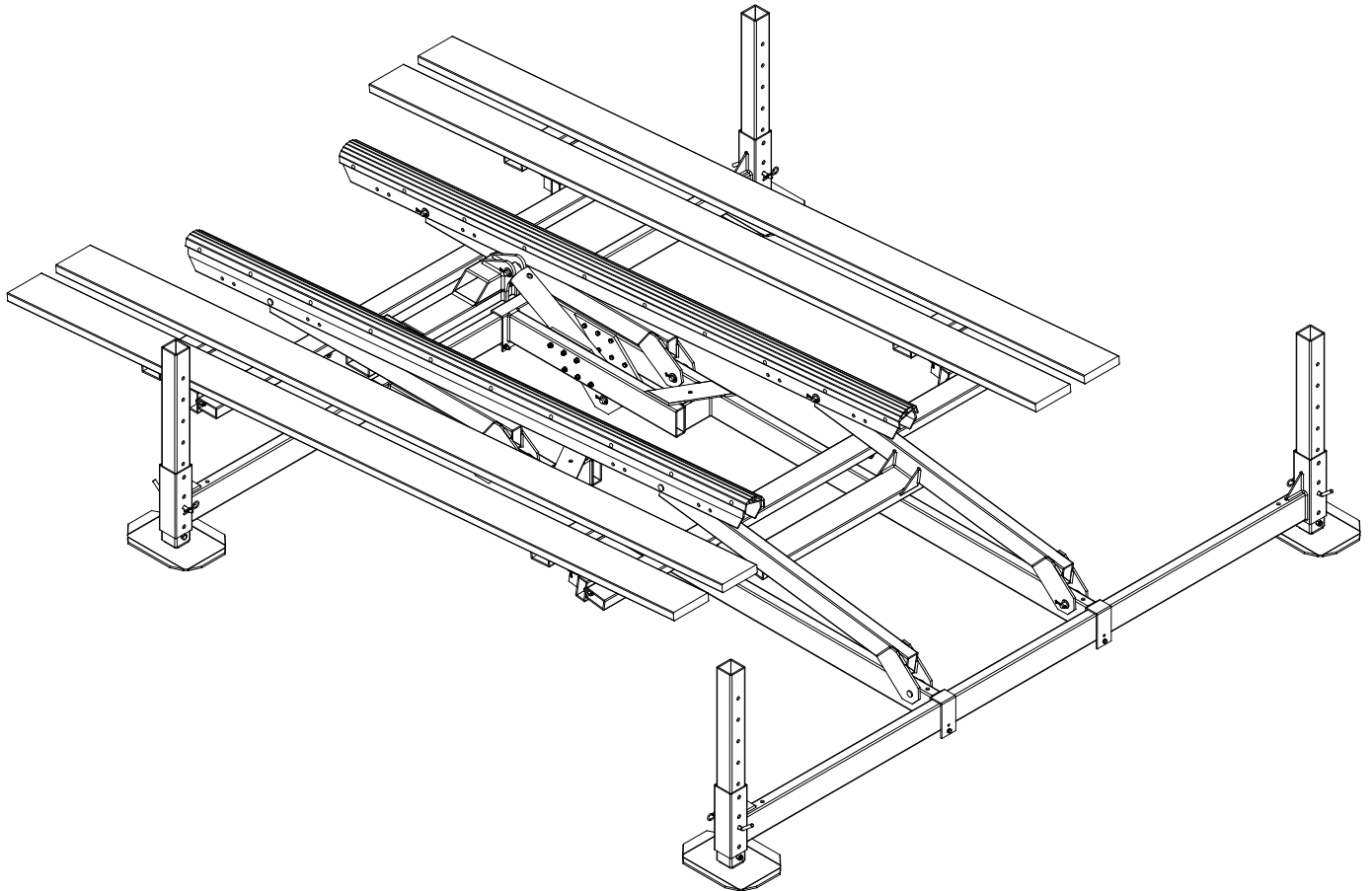

# HL4K PONTOON

## BOLT-ON KIT INSTRUCTIONS

(Applies to P/N 4113065)



REIMANN & GEORGER CORPORATION  
MARINE PRODUCTS  
P/N 6114181

BUFFALO, NY  
04/11/18

## TABLE OF CONTENTS

CHAPTER	TITLE	PAGE
<b>1</b>	<b>SAFETY .....</b>	<b>1</b>
1.1	Introduction .....	1
1.2	Safety Definitions .....	1
1.3	Equipment Safety Labels .....	1
1.4	Safety Rules .....	1
<b>2</b>	<b>INSTALLATION AND SETUP .....</b>	<b>3</b>
2.1	Pre-Installation Checks .....	3
2.2	Tools Required .....	3
2.3	HL4K Pontoon Cross Support .....	3
2.4	HL4K Pontoon Cross Support Tube Mounting .....	6
2.5	HL4K Pontoon Bunk Supports .....	7
2.6	HL4K Pontoon Wood Bunks Mounting .....	8
<b>3</b>	<b>PARTS LISTS.....</b>	<b>9</b>
3.1	HL4K Pontoon Bolt-On Kit Carton of Parts.....	9

## LIST OF FIGURES

FIGURE	DESCRIPTION.....	PAGE
2-1A	HL4K (48" Lift) Remove Bunks for Drilling .....	3
2-2A	HL4K (48" Lift) Drilling Liftarms.....	4
2-3A	HL4K (48" Lift) Drilling Liftarms- Views A&B.....	4
2-2B	HL4K (60" Lift) Drilling Liftarms.....	4
2-3B	HL4K (60" Lift) Drilling Liftarms- Views A&B.....	5
2-4A	HL4K (48" Lift) Cross Support Mounting .....	6
2-4B	HL4K (60" Lift) Cross Support Mounting .....	6
2-5A	HL4K (48" Lift) Pontoon Bunk Support Mounting.....	7
2-5B	HL4K (60" Lift) Pontoon Bunk Support Mounting.....	7
2-6A	HL4K (48" Lift) Pontoon Bunk Mounting .....	8

# 1 SAFETY

## 1.1 INTRODUCTION

our Reimann & Georger Corporation Marine Products HL Pontoon Bolt-On Kit is designed to lift boat by pontoons rather than deck and aid in proper positioning of boat on the lift. Your Pontoon Bolt-On Kit is well designed and well built. However, like any other equipment, it can malfunction or become hazardous in the hands of an inexperienced and/or untrained user. Therefore, read this manual and your related Vertical Lift manual, and related equipment manuals thoroughly before installing this kit and operating your lift to provide maximum safety for all operating personnel, and to get the maximum benefit from your equipment.

## 1.2 SAFETY DEFINITIONS

A safety message alerts you to potential hazards that could hurt you or others or cause property damage. The safety messages or signal words for product safety signs are **DANGER**, **WARNING**, and **CAUTION**. Each safety message is preceded by a safety alert symbol and is defined as follows:

**DANGER:** Indicates an imminently hazardous situation which, if not avoided, **will** cause death or serious injury. This safety message is limited to the most extreme situations.

**WARNING:** Indicates a potentially hazardous situation which, if not avoided, **could** result in death or serious injury.

**CAUTION:** Indicates a potentially hazardous situation which, if not avoided, **may** result in minor or moderate injury. It may also be used to alert against unsafe practices and property-damage-only accidents.

## 1.3 EQUIPMENT SAFETY LABELS

These labels warn you of potential hazards that could cause injury. Read them carefully. If a label comes off or becomes illegible, contact a Reimann & Georger Corporation dealer for a replacement.

## 1.4 SAFETY RULES



### **WARNING:**

**DO NOT INSTALL THIS KIT AND OPERATE THE LIFT WITHOUT READING BOTH THIS MANUAL AND YOUR HYDRAULIC LIFT MANUAL. FAILURE TO DO THIS CAN LEAD TO EQUIPMENT MISUSE WITH RESULTING DAMAGE AND/OR SERIOUS PERSONAL INJURY. CONTACT YOUR RGC® MARINE DEALER IF YOU HAVE ANY QUESTIONS.**

1. Do not install this kit without first replacing any damaged or defective parts.
2. The Pontoon kit does not increase the rated capacity of the lift. Never use the lift beyond its rated capacity. This can damage the kit assembly, lift, and/or boat with resulting serious personal injury.
3. Never try using any part of this kit in an application for which it was not designed.
4. Do not weld or otherwise modify any part of this kit. Such alterations may weaken the structural integrity of the lift and void the warranty.
5. Do not try installing the pontoon brackets or bumpers with the weight of the boat on the lift. This can cause equipment damage and/or personal injury.
6. The following precautions must be observed when lifting any part of this equipment:
  - a. Be sure of your footing.
  - b. Bend your knees and lift with your legs.
  - c. Hold the equipment section close to your body when lifting.
7. After the Pontoon kit is installed, the safety checks in Steps 8 through 25 must be performed on your lift prior to operation. Details on these checks are given in your vertical lift manual.

8. Before allowing anyone to operate the lift, be sure they fully understand the proper operating procedure.
9. Do not operate the lift under the influence of drugs, alcohol, or medication.
10. Keep people and pets clear during operation of the lift.
11. Keep fingers and clothing clear of all moving parts.
12. Never allow people in the boat any time it is suspended above the water on the platform.



**WARNING:**

**DO NOT STAND OR WALK ON THE PLATFORM WHILE IT IS IN ANY RAISED POSITION. THIS CAN CAUSE SERIOUS PERSONAL INJURY.**

13. Do not allow anyone to swim or play under, near or on the lift at any time.
14. Insure that all bolts and nuts are fastened securely on both this kit and the lift prior to operation.
15. Insure that the frame is level and square.
16. Completely remove any user or dealer installed locking devices before operating the lift.
17. Ensure the center of gravity of the boat is between forward tube and rear foot plates. The boat must be secured on the lift before raising or lowering. Failure to do this can cause equipment damage and/or serious personal injury.
18. The boat must be stored with the lift in the over center position.
19. A clear visual path is required when using remote transmitter. Obstacles, radio frequency interference, and weak transmitter batteries will degrade the performance and range of your remote transmitter.
20. Never adjust or service the lift during operation or while connected to the control box.
21. Do not adjust components in the control box while operating the lift.
22. Completely lower the platform before performing any type of maintenance or repair.



**WARNING:**

**ALL ELECTRIC DRIVES MUST BE INSTALLED AND INSPECTED BY A CERTIFIED ELECTRICIAN IN ACCORDANCE WITH LOCAL ELECTRICAL CODES. THIS INSTALLATION MUST INCLUDE A PROPERLY WORKING GROUND FAULT CIRCUIT INTERRUPTER. (G.F.C.I.)**

23. Never use the lift to hang or store any auxiliary equipment such as boating hardware.
24. At end of operation, secure the control box and the lift to prevent unauthorized use. Never assume you will find the equipment in the same condition in which you left it.
25. Never operate the remote control or hydraulic power unit when connecting or disconnecting hydraulic hoses.

## 2 INSTALLATION AND SET UP

### 2.1 RE-INSTALLATION CHECKS

1. Do not assemble this kit or any other component of the lift if any part appears to be damaged.
2. Do not weld or other wise modify any portion of the lift. Such alterations may weaken the structural integrity of the lift and void the warranty.

### 2.2 TOOLS REQUIRED

1. 3/4" Wrench or Adjustable Wrench.
2. Drill Motor.
3. 9/16" drill bit.

**Please NOTE;** If additional cushioning is desired carpet can be wrapped around the wood.



### CAUTION:

**AT A MINIMUM, THIS KIT SHOULD BE INSTALLED USING THIN CARPET, RUBBER, OR CORK SHEETING AS A BARRIER BETWEEN PRESSURE TREATED WOOD AND ALUMINUM MOUNTING BRACKETS. FAILURE TO INSTALL A BARRIER COULD SHORTEN THE LIFE EXPECTANCY OF THIS KIT OR PONTOON MATERIAL. CONTACT YOUR RGC® MARINE DEALER IF YOU HAVE ANY QUESTIONS.**

### 2.3 HL PONTOON CROSS SUPPORTS

1. **Refer to Figure 2-1, 2-2 & 2-3.** Remove HL bunks to access the liftarms for drilling holes. Layout the holes shown in figure 2-2 & 2-3. Drill holes through front & rear liftarms.

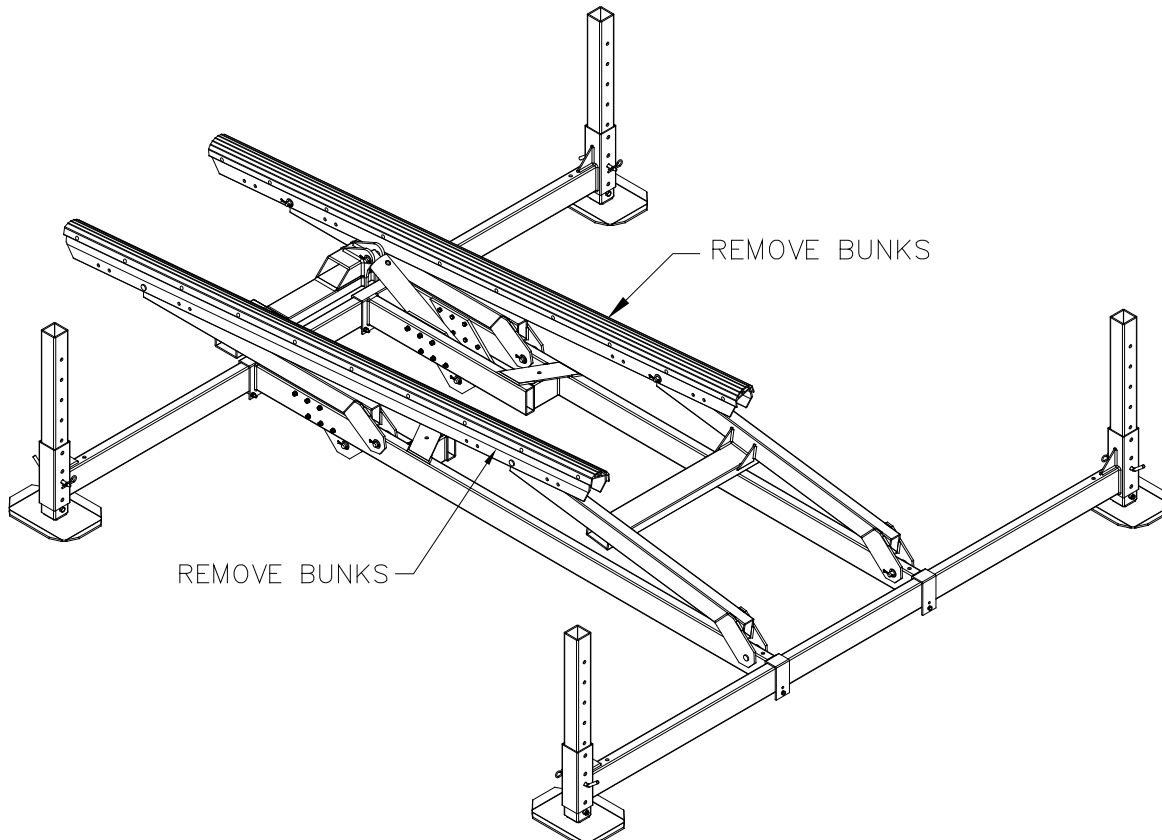

**Figure 2-1A.**  
**HL4K (48" Lift) Remove Bunks for Drilling liftarms.**

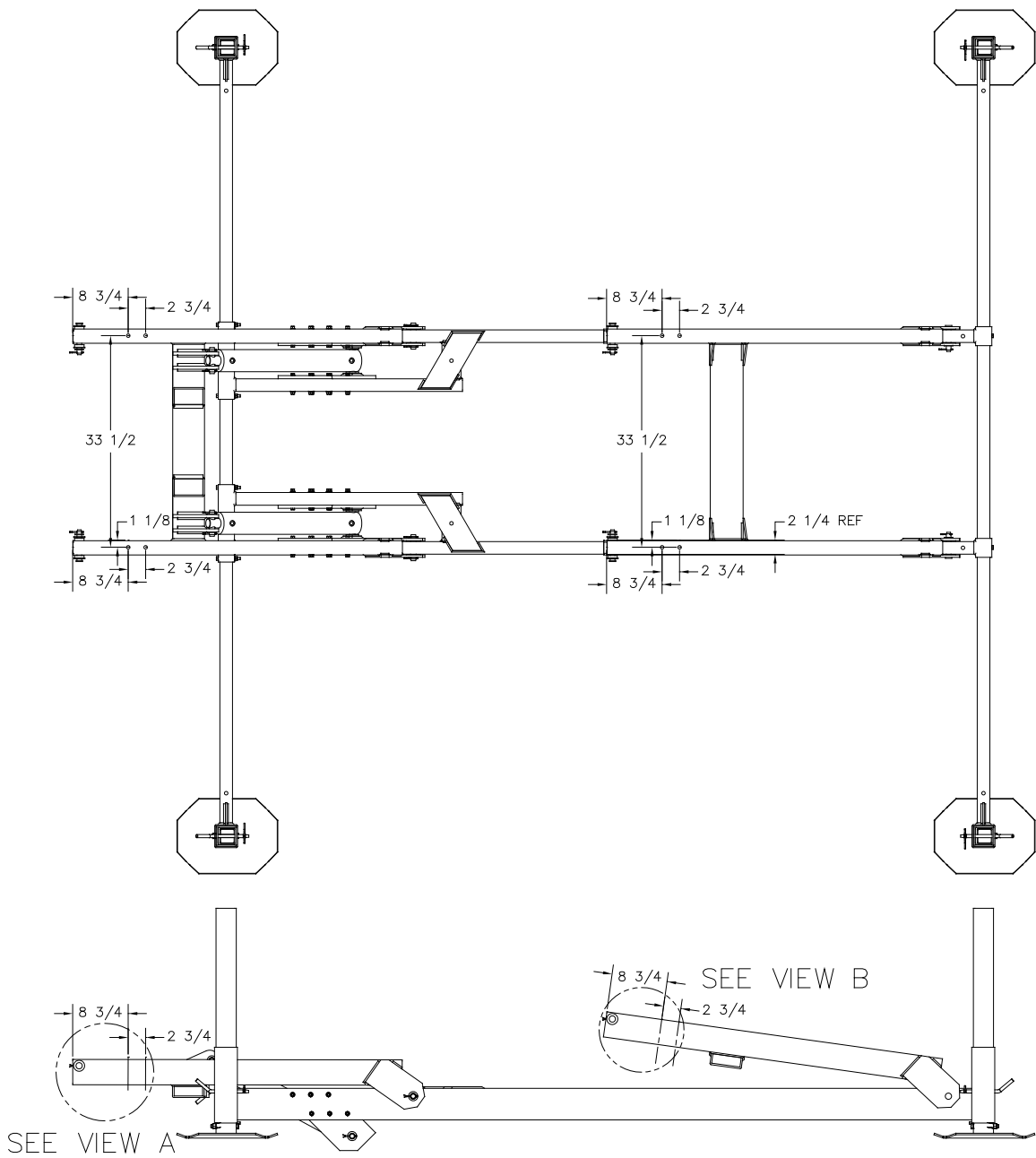

**Figure 2-2A.**  
**HL4K (48" Lift) Drilling liftarms.**

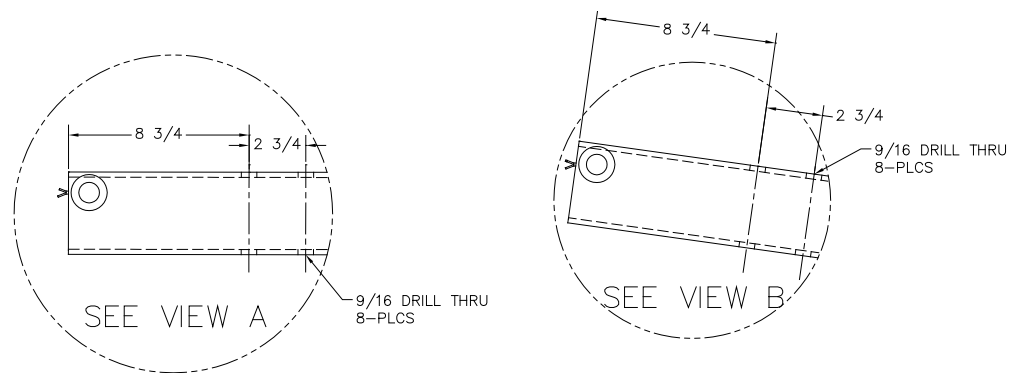

**Figure 2-3A.**  
**HL4K (48" Lift) Drilling liftarms.**

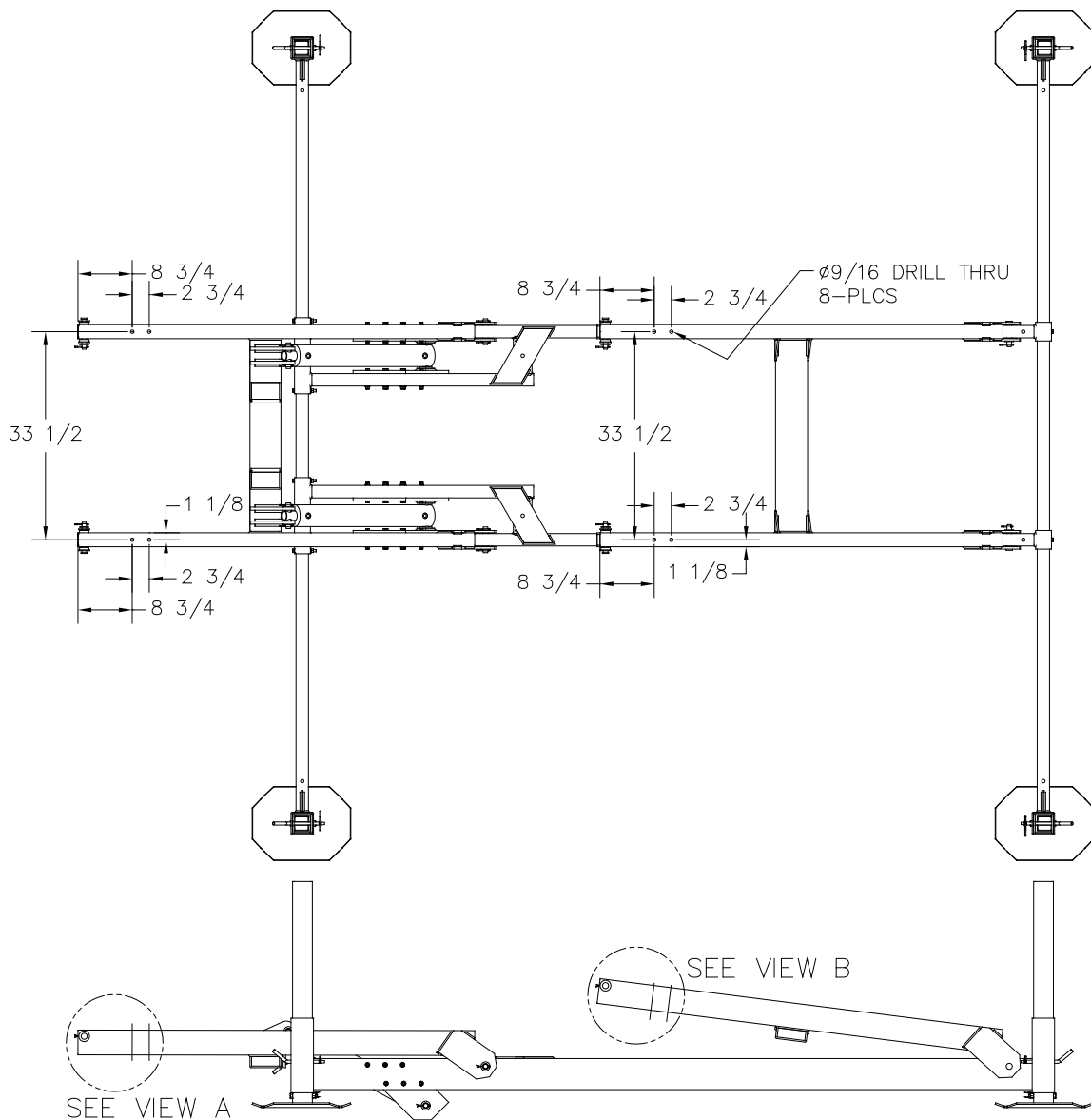

**Figure 2-2B.**  
**HL4K (60" Lift) Drilling liftarms.**

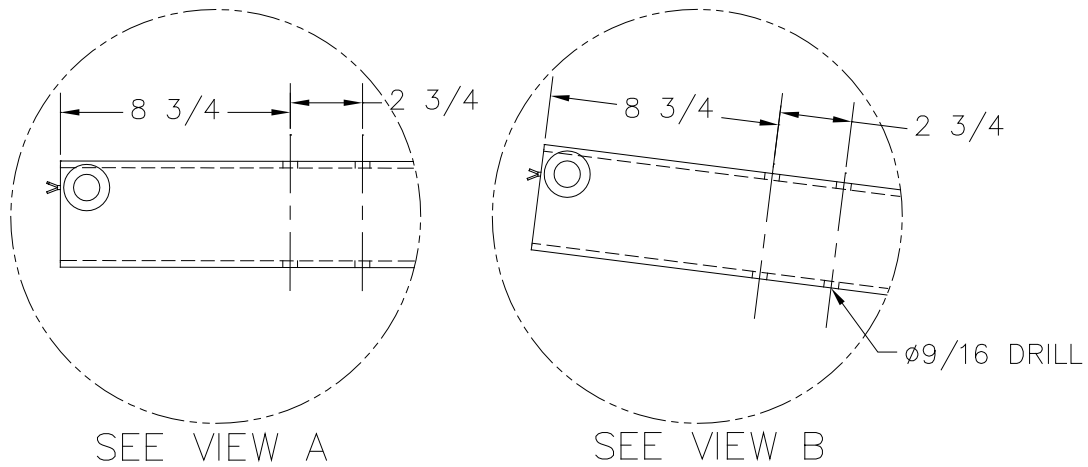

**Figure 2-3B.**  
**HL-4K (60" Lift) Drilling liftarms**

2.4 HL4K PONTOON CROSS SUPPORT TUBE MOUNTING

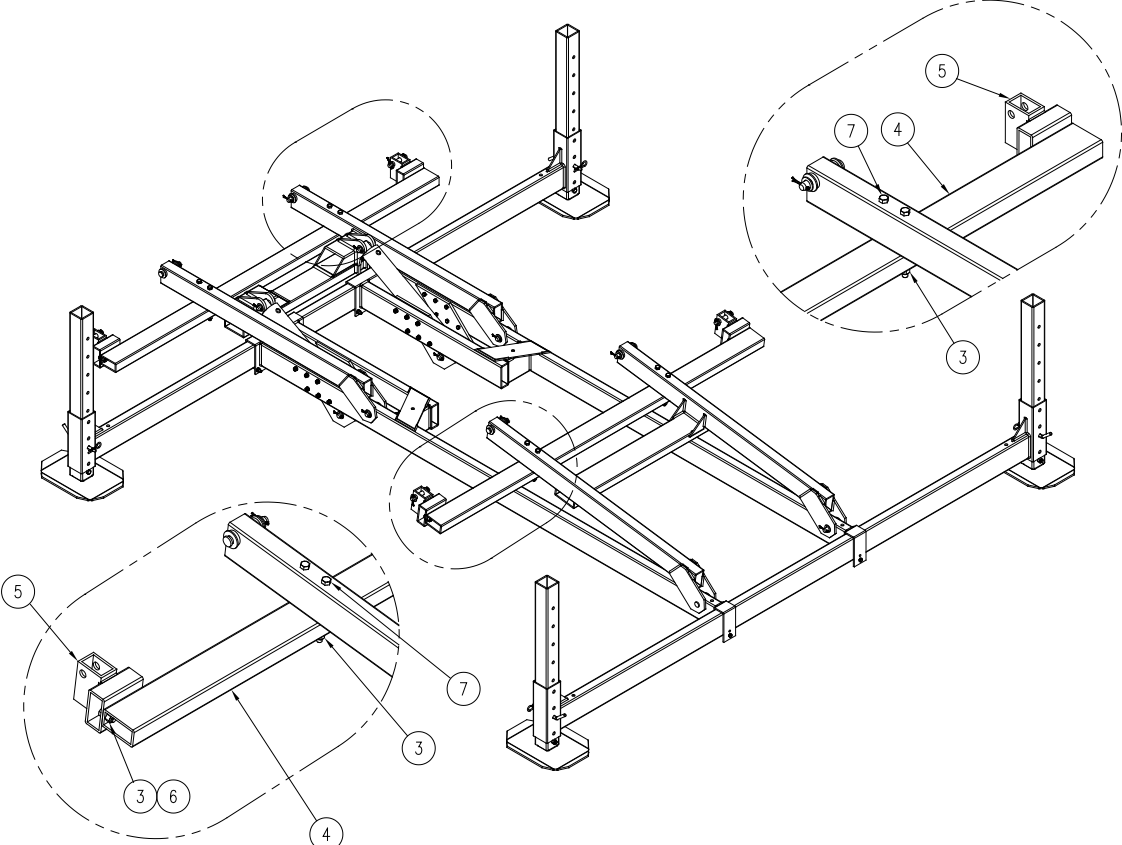

Figure 2-4A.  
HL4K (48" LIFT) Cross Support Mounting

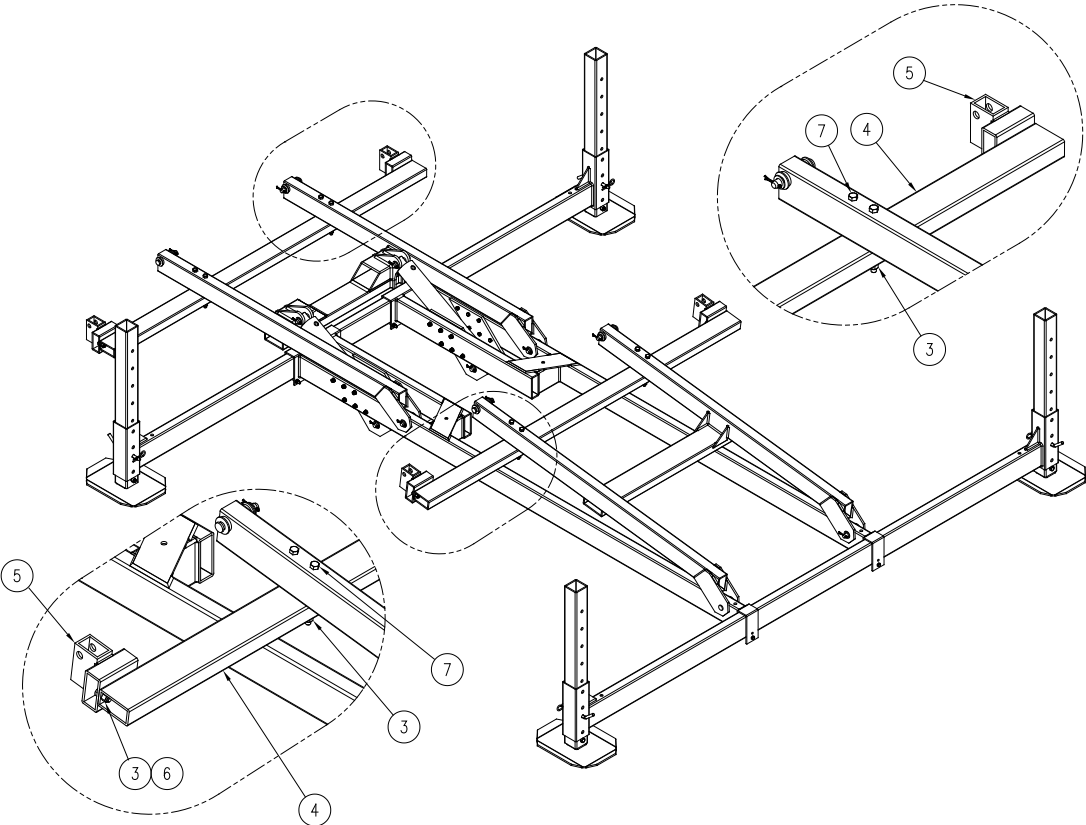
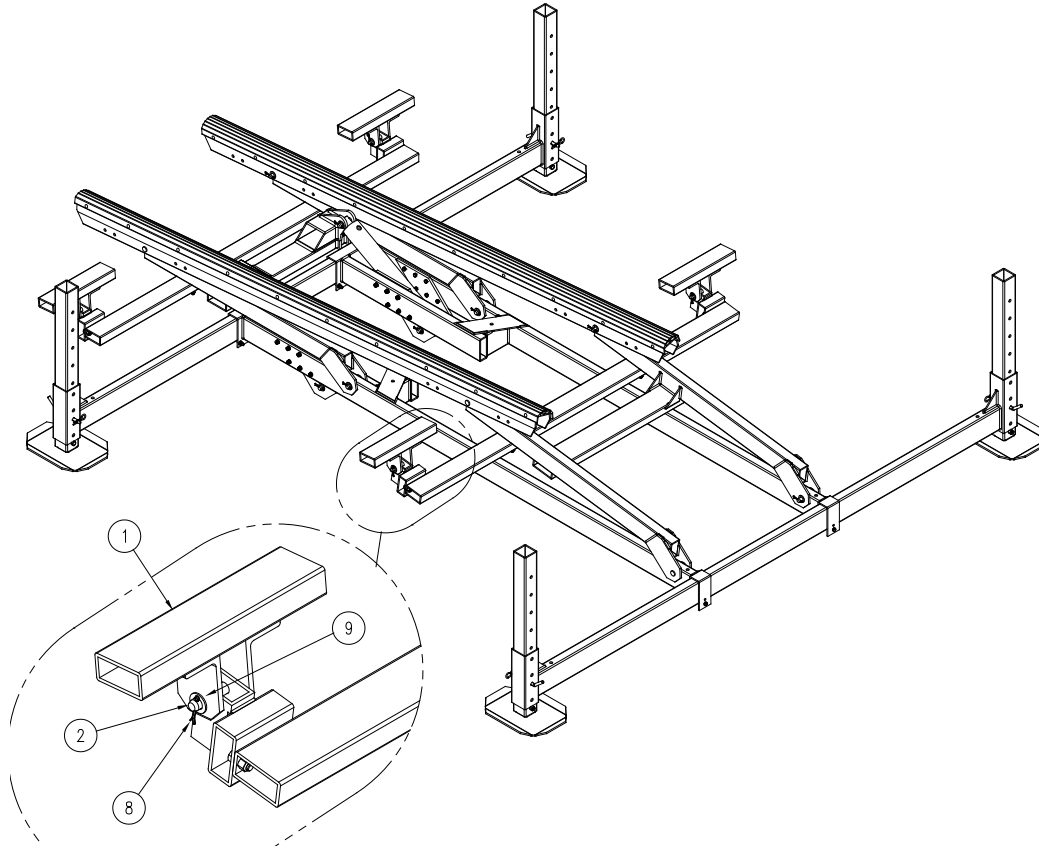

Figure 2-4B.  
HL4K (60" LIFT) Cross Support Mounting



## 2.5 HL4K PONTOON BUNK SUPPORTS



**Figure 2-5A.**  
**HL4K (48" Lift) Pontoon Bunk Support Weldment**

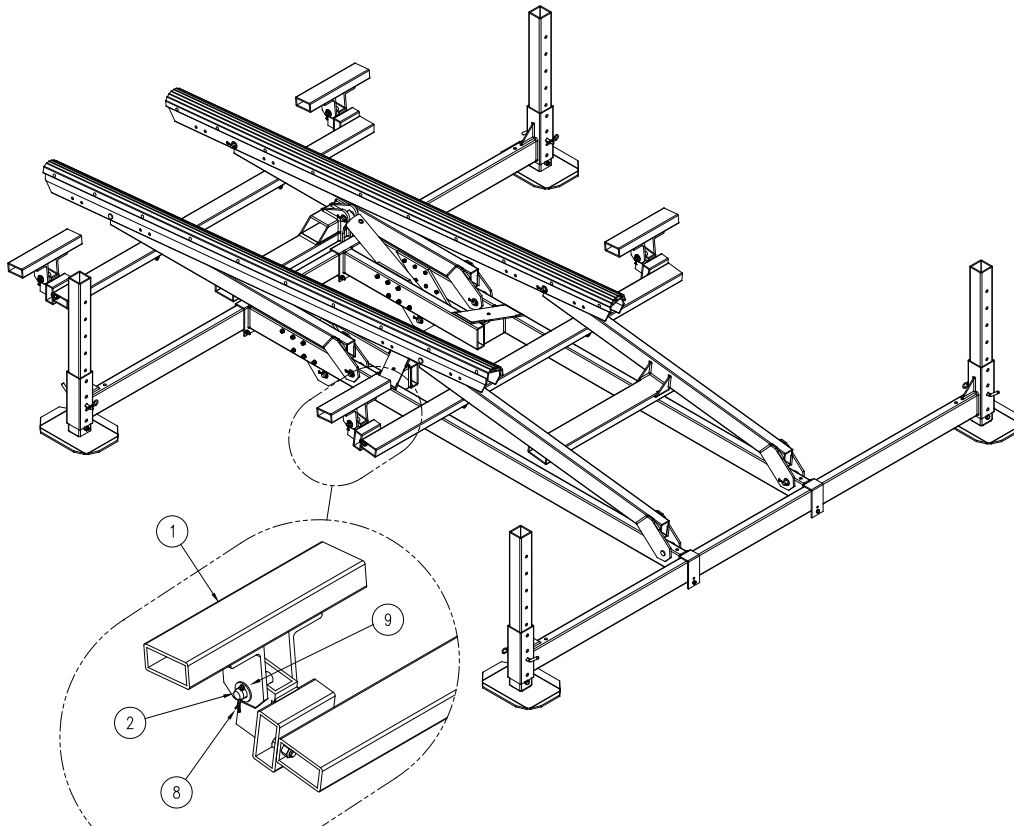

**Figure 2-5B.**  
**HL4K (60" Lift) Pontoon Bunk Support Weldment**

## 2.6 HL4K (48" Lift) PONTOON MOUNT WOOD BUNKS

(4) 2" x 8" x 12' wood bunks (bunks not supplied). Use carriage bolts 3/8-16 x 2-1/2" stainless & hex nut (not supplied).

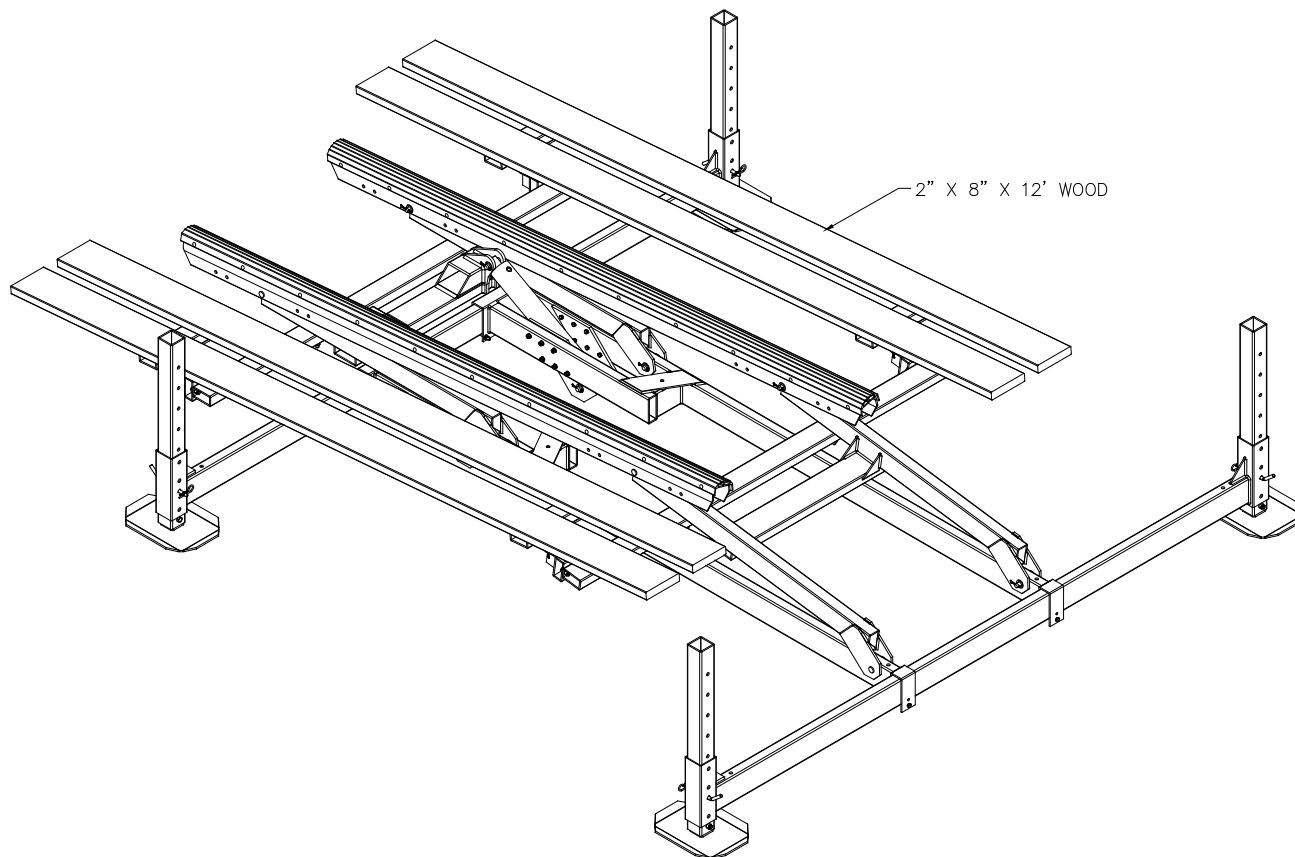

**Figure 2-6A.**  
**HL4K (48" Lift) Pontoon Bunk Mounting**

### 3 HL4K PONTOON BOLT-ON KIT INSTRUCTIONS

#### 3.1 411065 HL4K PONTOON BOLT-ON KIT (USED ON BOTH 48" & 60" LIFT)

Reference	Part Number	Quantity	Description
1	4113524	4	HL PONTOON BUNK SUPT WELDMENT
2	4107914	4	HL CLEVIS PIN 3/4 X 4-3/8 SS
3	5897018	16	NUT HEX NYLOCK 1/2-13 SS
4	4113731	2	HL PONTOON CROSS SUPT TUBE 83"
5	4113527	4	HL PONTOON PIVOT TUBE WELDMENT
6	5896281	8	HHCS 1/2-13 X 1-1/4 SS
7	5894006	8	HHCS 1/2-13 X 7 SS
8	5894108	8	PIN, COTTER 5/32 X 1-3/4 SS
9	5896417	8	WASHER FLAT SAE 3/4 SS

#### RECOMMENDED WOOD (NOT INCLUDED)

- 4 PCS 2" x 8" x 12' PRESSURE TREATED WOOD

## **TWO YEAR LIMITED WARRANTY**

### **Reimann & Georger Corporation Marine Products**

This product is warranted by RGC® Marine Products to the original purchaser to be free from defects in material and workmanship under normal use for a period of two years from the date of purchase.

During the warranty period, and upon proof of purchase, the product will be repaired or replaced (with the same or similar model) at our option, without charge for either parts or labor when serviced at RGC® Marine Products.

Upon completion of repair, the unit will be returned to the customer freight prepaid. The warranty will not apply to this product if it has been misused, abused, or altered.

NEITHER THIS WARRANTY OR ANY OTHER WARRANTY, EXPRESS OR IMPLIED, INCLUDING IMPLIED WARRANTIES OF MERCHANTABILITY, SHALL EXTEND BEYOND THE WARRANTY PERIOD. NO RESPONSIBILITY IS ASSUMED FOR ANY INCIDENTAL OR CONSEQUENTIAL DAMAGES. SOME STATES DO NOT ALLOW EXCLUSION OR LIMITATION OF INCIDENTAL OR CONSEQUENTIAL DAMAGES, SO THE ABOVE LIMITATIONS OR EXCLUSIONS MAY NOT APPLY TO YOU.

This warranty gives you specific legal rights, and you may also have other rights which vary from state to state.